



Worcester County

BOARD OF LICENSE COMMISSIONERS

MEMBERS

R. CHARLES NICHOLS, CHAIRMAN

MARTY W. PUSEY

REESE F. CROPPER, III

WILLIAM E. ESHAM, III, ALTERNATE

LIQUOR LICENSE ADMINISTRATOR

APRIL R. PAYNE

apayne@worcestermd.gov

ATTORNEY

W. HANK FISHER, III

www.co.worcester.md.us/departments/drpl/liquor-licensing

AGENDA
BOARD OF LICENSE COMMISSIONERS
JUNE 17, 2026

The public is invited to view this meeting live online at - <https://worcestercountymd.swagit.com/live>
This portion of the meeting is an Open Meeting; it will be recorded and available online

1:00 - Administrative Matters and Approval of Minutes

1:05 - Application for Class “B” B/W/L 7 Day License
T/A: 2EZ Coastal Restaurant & Lounge
5401 Coastal Highway/Ocean City

1:20 - Application for Class “A” B/W 7 Day License
T/A: Valero
11121 Racetrack Road/Berlin

Postponed

1:20 - Meeting/Taphouse West – (License #911)
Class “B” B/W/L 7 Day License
Request to expand the licensed premises
Request for multiple outside games
12513 Ocean Gateway/Ocean City

1:30 - Meeting/Caruso Pizza & Wild Bill’s – (License #816)
Class “B” B/W/L 7 Day License
Request to expand the licensed premises for Bike Week on September 9, 2026 - September 12, 2026 during the hours of 12 p.m. until 12 a.m. in adjacent parking lot
Request for live entertainment for Bike Week on September 9, 2026 - September 12, 2026 during the hours of 12 p.m. until 12 a.m. in adjacent parking lot
Request to redefine the licensed property
420 Atlantic Avenue & Boardwalk/Ocean City

1:45 - Meeting/Flamingo Coast – Vault & Laguna Rooftop Lounge – (License #113)
Class “B” B/W/L 7 Day License
Request to change live entertainment hours from 3 p.m. until 11 p.m. to 12 noon until 11 p.m.
3 N. Division Street & Boardwalk/Ocean City

1:55 - Meeting/Bearded Clam – (License #10)
Class “D” B/W/L 7 Day License
Request to expand the licensed premises
Request to add an outside bar to licensed premises
Request for one cornhole game, and one board game be allowed in the outside bar area
15 Wicomico Street/Ocean City

2:20 – Meeting/NAVBETS – Orlando H. Smack Jr., Chapter #0129
Special One Day Per Diem Application for June 27, 2026
Discussion to determine non-profit status
407A Tingle Street/Snow Hill

Worcester County Board of License Commissioners
Open Meetings Act Minutes
May 20, 2026

Time: 1:00 P.M

Location: Worcester County Governmental Center, Board Room, Room 1102

Attendance:

License Commissioners

R. Charles Nichols

Marty W. Pusey

Staff:

Thomas Coates, Esquire

April R. Payne, Liquor License Administrator

Joseph Pembroke, Liquor License Inspector

I. Call to Order

II. Administrative Matters

The Board of License Commissioners reviewed the minutes from the April 15, 2026, meeting, and a motion was made by Commissioner Pusey seconded by Chairman Nichols and carried unanimously to approve the minutes as submitted.

III. Closed Session - Administrative Matters

Thomas Coates, Esquire, reported that the legislature has adopted the Class “C” Municipal Events to-Go Licenses and temporary to-go permits. These changes authorize Worcester County to issue alcoholic beverage licenses with a temporary to-go permit. He noted that the statute outlines the applicable rules and regulations, which will take effect on July 1, 2026. Chairman Nichols stated that an additional meeting will be scheduled, with all members present, to review the rules and regulations in detail.

IV. Open Session

No administrative matters were discussed during Open Session.

V. Adjournment

WORCESTER COUNTY BOARD OF LICENSE COMMISSIONERS
 MINUTES FOR CYPRESS RIVER INN & SPA – NEW APPLICATION
 MAY 20, 2026

Members Present:		R. Charles Nichols, Chairman		<input checked="" type="checkbox"/>	Marty W. Pusey	<input checked="" type="checkbox"/>	Reese Cropper, III	<input type="checkbox"/>
		Alternate Board Member: William E. Esham, III		<input type="checkbox"/>				
Staff Present:		April Payne, Administrator		<input checked="" type="checkbox"/>	Joe Pembroke, Inspector		<input checked="" type="checkbox"/>	
		Hank Fisher III, Esq., Board Attorney		<input type="checkbox"/>	Alternate Board Attorney: Name: Thomas Coates, Esq.		<input checked="" type="checkbox"/>	
		Stacey Odell, Administrative		<input checked="" type="checkbox"/>	Valarie Dawson, Court Reporter		<input checked="" type="checkbox"/>	
License #:	NEW	Hearing Date:	May 20, 2026		Hearing Start Time:	1:05 p.m.		
Class:	"B"	Type:	B/W/L		Day:	7 Day		
For: Cypress River Inn & Spa, LLC.		T/A: Cypress River Inn & Spa		Address: 201 East Market Street Snow Hill Maryland 21863				
New Application:	<input checked="" type="checkbox"/> Yes	Transfer:	<input type="checkbox"/> Yes		Meeting:	<input type="checkbox"/> Yes		Violation: <input type="checkbox"/> Yes
Items to be discussed: Application for Class "B" B/W/L 7 Day License.								
Applicants:	<input checked="" type="checkbox"/>	Licensees:	<input type="checkbox"/>		Representative:			
1. Tammie Faille					1. Christopher Woodley, Esquire			
2. Jeffrey Faille					2.			
3. Darren Casto					3.			
Witnesses:					Prototants:			
1.					1.			
Exhibits:					Exhibits			
1. Applicant's Exhibit #1 – Arial Site Plan					1.			
2. Applicant's Collective Exhibit #2 – Photographs – Front & Back of House, Porch, Gazebo, Bar								
3. Applicant's Exhibit #3 – Restaurant Floor P								
<p>Hearing Minutes: The applicants Tammie Faille, Jeffrey Faille, and Darren Casto accompanied by their attorney Christopher W. Woodley, Esquire appeared before the Board seeking approval for an Application for Class "B" B/W/L 7 Day License for Cypress River Inn & Spa. The applicants were sworn in. Board Attorney Thomas Coates, Esquire, entered (Applicant's Exhibit #1), Arial Site Plan. Woodley stated for the record that Catherine Casto, a member of the LLC, could not attend due to her obligations as an OBGYN with scheduled patient appointments and requested that she be excused. Woodley stated that the property located at 201 East Main Street, Snow Hill, was purchased in March 2026 by Tammie & Jeffrey Faille and Darren & Catherine Casto. T. Faille described the property layout as follows, the front portion of the main house is the historic George Washington Purnell House built 1853, a rear porch with a two-story porch cover, a pathway leading to the existing swimming pool, which will be converted into a Koi pond, a three-room cottage, a one-room cottage, a two-story cottage near the Pocomoke River with front and back porches, the property is fenced on all sides except the open view toward the river, there is currently a fence around the pool, which will be removed as part of the Koi pond conversion.. T. Faille stated that seating for 32 guests will be arranged around the pond (four guests per table). The bar will be located approximately eight feet from the pond and seat four to five people. She confirmed that liquor will not be stored at the outdoor bar overnight; it will be removed and secured inside the storage room or basement nightly. Woodley stated that the applicants are requesting to license the entire property, including cottages and outdoor areas, so that guests may legally carry beverages throughout the grounds, including to their rooms. They would also like to offer wine or champagne delivery to guest rooms, as is common for similar venues. T. Faille added that they regularly hold weddings at other venues and would like to host weddings onsite at Cypress River Inn & Spa. Woodley asked J. Faille, who will serve as Head Chef, to explain his role. Mr. Faille stated that the restaurant will offer Uber Fine Dining, serving dishes such as rack of lamb, tenderloin, escargot, and other items</p>								

WORCESTER COUNTY BOARD OF LICENSE COMMISSIONERS
 MINUTES FOR CYPRESS RIVER INN & SPA – NEW APPLICATION
 MAY 20, 2026

reflective of his formal Culinary School training. He explained that guests enjoying a filet or tenderloin typically expect a quality wine or cocktail pairing, not water or soda, which demonstrates the importance of the liquor license for proper fine-dining service. Woodley stated the applicants have already invested approximately \$500,000 in property improvements and renovations, with all applicants actively involved in the work. T. Faille stated they plan to keep weddings intimate, with approximately 100 guests, and would use a 16' x 60' tent with enough staff to ensure effective supervision. Board Attorney Coates entered (Applicant's Collective Exhibit #2), photographs of the front & back of the home, porch, and planned gazebo/bar location. The Board Administrator April Payne asked about alcohol service on the back porch. T. Faille stated there will be no alcohol served on the back porch, as it is part of the kitchen area and reserved for employees only. Chairman Nichols recommended including the porch in the licensed premises to avoid confusion. T. Faille agreed. Board Attorney Coates entered (Applicant's Exhibit #3), restaurant floor plan; which notes seating for 8 guests, covered porch seating for 12 guests, and the second-floor layout with four updated bedrooms. Chairman Nichols noted that the parcel is 2.13 acres and appears fully fenced. T. Faille confirmed it is fenced on all sides except where it meets the woods, and that the front has an iron fence. T. Faille stated she will serve as General Manager, and is TIPS/TAM certified, and will ensure all staff are also certified. She noted that they currently handle food service at Burley Beer in Berlin using two food trucks. Hours of operation will begin at 10:00 a.m. or 8:00 a.m. daily, closing at 9:00 p.m., and 10:00 p.m. for weddings. Woodley stated that the applicants are not requesting any entertainment, either indoors or outdoors. Only soft background music will be used, with two exterior speakers. A music technician will be used for weddings only. Woodley confirmed he provided the applicants with the Liquor Board's rules and regulations, and they understand that violations or future changes to the premises will require them to reappear before the Board. T. Faille confirmed she is the Resident Agent and obtained all required signatures for the license application. Commissioner Pusey asked about music lasting until 9:00 p.m. T. Faille stated the music will be soft, "elevator-style" background music, not loud. Commissioner Pusey asked whether she had spoken with neighboring residents. T. Faille stated they have only one close neighbor and she has spoken with them and others in the area, all of whom expressed excitement for the project. Chairman Nichols noted that a parking lot is adjacent to the property and there were no protestants present. Chairman Nichols asked whether the koi pond would be completed soon and confirmed it will not be used as a swimming pool. Casto stated it will not be used as a swimming pool, the cover will remain on until construction begins, and there is currently no water in the pool. Commissioner Pusey asked whether the applicants were requesting off-sale alcohol. Mrs. Faille replied "No."

The Board tentatively approved the application for a Class "B" B/W/L 7 Day License for Cypress River Inn & Spa, pending all required documentation.

Motion:	1st	Ms. Pusey	2nd	Mr. Nichols	Approved:	X	Yes	<input type="checkbox"/>	No
----------------	-----	-----------	-----	-------------	------------------	---	-----	--------------------------	----

Restrictions: NO LIVE ENTERTAINMENT INSIDE OR OUTSIDE, NO DISC JOCKEY ALLOWED, BACKGROUND MUSIC ALLOWED INSIDE PROPERTY, MUSIC TECHNICIAN ALLOWED FOR WEDDINGS UNTIL 10 P.M. IN BACK YARD AREA, TWO OUTSIDE SPEAKERS ALLOWED IN OUTSIDE BAR AREA UNTIL 10 P.M., NO GAMES ALLOWED, NO POOL TABLES ALLOWED, NO OFF SALE, ENTIRE PREMISES LICENSED.

Time Hearing Ended: 1:25 p.m.

WORCESTER COUNTY BOARD OF LICENSE COMMISSIONERS
MINUTES FOR TIDE TO TABLE – NEW APPLICATION
MAY 20, 2026

Members Present:		R. Charles Nichols, Chairman		<input checked="" type="checkbox"/>	Marty W. Pusey	<input checked="" type="checkbox"/>	Reese Cropper, III	<input type="checkbox"/>
		Alternate Board Member: William E. Esham, III		<input type="checkbox"/>				
Staff Present:		April Payne, Administrator		<input checked="" type="checkbox"/>	Joe Pembroke, Inspector			<input checked="" type="checkbox"/>
		Hank Fisher III, Esq., Board Attorney		<input type="checkbox"/>	Alternate Board Attorney: Name: Thomas Coates, Esq.			<input checked="" type="checkbox"/>
		Stacey Odell, Administrative		<input checked="" type="checkbox"/>	Valarie Dawson, Court Reporter			<input checked="" type="checkbox"/>
License #:	NEW	Hearing Date:	May 20, 2026		Hearing Start Time:	1:25 p.m.		
Class:	"B"	Type:	B/W/L		Day:	7 Day		
For: Wisewell Ct., LLC.		T/A: Tide to Table		Address: 7805 Coastal Highway Ocean City, Maryland 21842				
New Application:	<input checked="" type="checkbox"/> Yes		Transfer:	<input type="checkbox"/> Yes		Meeting:	<input type="checkbox"/> Yes	
Violation:	<input type="checkbox"/> Yes							
Items to be discussed: Application for Class "B" B/W/L 7 Day License.								
Applicants:	<input checked="" type="checkbox"/>		Licensees:	<input type="checkbox"/>		Representative:		
1. Kevin Decker			1. Mark Spencer Cropper, Esquire					
2. Jason Elliott			2.					
3. Michael Wroten			3.					
Witnesses:			Protstants:					
1. Robert Bassitt			1.					
Exhibits:			Exhibits					
1. Applicant's Exhibit #1 – Renderings 1 st & 2 nd Floor seating			1.					
2. Applicant's Exhibit #2 –Robert Bassitt's Resume			2.					
<p>Hearing Minutes: The applicants Kevin Decker, Jason Elliott and Michael Wroten accompanied by their attorney Mark S. Cropper, Esquire appeared before the Board seeking approval for an Application for Class "B" B/W/L 7 Day License. The applicants were sworn in, along with Robert Bassitt (witness). Cropper stated the application before the Board is for the premises formerly known as Mother's Cantina. He confirmed that Decker is the Resident Agent, and asked Decker whether he completed the application accurately and obtained all required signatures and affidavits. Decker agreed. Cropper asked members Elliott and Wroten the same, both agreed. Cropper explains that the license applicants operate under Wisewell Ct., LLC, and the restaurant will be called Tide to Table. Board attorney Thomas Coates submitted (Applicant's Exhibit #1) renderings of seating of 1st & 2nd floor. Cropper explained that the renderings also include notations showing small, flush-mounted speakers on both floors. He stated the applicants request permission to play background music only, controlled by the manager or person on duty. Cropper entered (Applicant's Exhibit #2), Robert Bassitt's resume; Cropper stated that Bassitt has extensive professional and educational experience in bar and restaurant management and has agreed to serve as the General Manager (GM) of Tide to Table, overseeing hiring, firing, staffing, and operations. Bassitt confirmed his role. Cropper noted that, based on Bassitt's experience, all employees will be required to be TIPS/TAM certified. Bassitt stated he intends to begin restaurant operations by June 1, 2026, beginning with employee training and bringing in a trainer to work with the management team. Cropper reviewed the proposed seating, first floor: 70 inside, 18 outside, second floor: 53 inside, 82 outside. He confirmed the applicants are not requesting any live entertainment, pool tables, or games, and intends for the business to operate strictly as a restaurant/bar for patrons. Cropper noted that Resident Agent Decker has served in the same role at multiple licensed establishments, including The Angler Restaurant, Topsy Taco, OC Eateries, Mother's Cantina, and Lazy Lizard, with only one prior violation. Decker confirmed he will be spending regular time at the location. The applicants stated they will be offering a seafood focused menu. Cropper asked Elliott</p>								

WORCESTER COUNTY BOARD OF LICENSE COMMISSIONERS
 MINUTES FOR TIDE TO TABLE – NEW APPLICATION
 MAY 20, 2026

and Wroten how frequently they plan to be present at the location; both estimated twice per month or as needed, with Bassitt serving as the GM full-time. Chairman Nichols asked whether the applicants had previously held licenses and confirmed the lease is in good order. Decker responded “Yes.” Commissioner Pusey confirmed with the applicants that they plan to offer background music only, and they agreed. Chairman Nichols asked how many employees they expect to hire. Bassitt stated they will have approximately 8–12 kitchen staff and 20 front-of-house staff, with the total number subject to change depending on part-time and full-time needs. The business will operate year-round. Board Attorney Coates asked whether the settlement on the property had been completed. Decker confirmed it had. Chairman Nichols informed the applicants that they must post a sign at the gate to the parking lot stating, “No alcoholic beverages past this point.”

The Board tentatively approved the application for Tide to Table for a Class “B” B/W/L 7 Day license, pending all required documentation.

Motion:	1st	Ms. Pusey	2nd	Mr. Nichols	Approved:	X	Yes	<input type="checkbox"/>	No
Restrictions: NO LIVE ENTERTAINMENT, NO DISC JOCKEY ALLOWED, NO GAMES ALLOWED, NO POOL TABLES ALLOWED, BACKGROUND MUSIC ALL WED INSIDE AND ON OUTSIDE DECK AREAS, NO OFF SALE.									
Time Hearing Ended: 1:38 p.m.									

DRAFT

WORCESTER COUNTY BOARD OF LICENSE COMMISSIONERS
MINUTES FOR EMBERS RESTAURANT & BLU CRABHOUSE – LICENSE #18
MAY 20, 2026

Members Present:		R. Charles Nichols, Chairman		X	Marty W. Pusey	X	Reese Cropper, III	<input type="checkbox"/>
		Alternate Board Member: William E. Esham, III		<input type="checkbox"/>				
Staff Present:		April Payne, Administrator		X	Joe Pembroke, Inspector			X
		Hank Fisher III, Esq., Board Attorney		<input type="checkbox"/>	Alternate Board Attorney: Name: Thomas Coates, Esq.			X
		Stacey Odell, Administrative		X	Valarie Dawson, Court Reporter			X
License #:	18	Hearing Date:	May 20, 2026		Hearing Start Time:	1:39 p.m.		
Class:	"B"	Type:	B/W/L		Day:	7 Day		
For: The Embers Restaurant, Inc.		T/A: Embers Restaurant & Crabhouse		Address: 2305 Philadelphia Avenue Ocean City, Maryland 21842				
New Application:	<input type="checkbox"/> Yes	Transfer:	<input type="checkbox"/> Yes		Meeting:	X Yes		Violation: <input type="checkbox"/> Yes
Items to be discussed: Class "B" B/W/L 7 Day License Request off-sale of liquor from the third-floor area once per week during organized tasting events restricted to the specific alcoholic beverages offered at the event.								
Applicants:	<input type="checkbox"/>	Licensees:	X		Representative:			
1. Cole Taustin					1. Hugh Cropper, Esquire			
2. Jay Taustin					2.			
Witnesses:					Protestants:			
1.					1. Sara Hambury – West O Bottle Shop (Opposed)			
2.					2 Sam Ramadan – Village Market Beer, Wine & Liquor (Opposed)			
3.					3. Richard Smith – Village Market Beer, Wine & Liquor (Opposed)			
4.					4. Jeff Walls – 8th Street Liquors (Opposed)			
Exhibits:					Exhibits:			
1. Applicant's Exhibit #1 – Photo Screen replacing glass door					1.			
2. Applicant's Exhibit #2 – Photo – Proposed venue area					2.			
<p>Hearing Minutes: Licensees Cole Taustin and Jay Taustin along with their attorney Hugh Cropper, Esquire appeared before the Board for a Class "B" B/W/L 7 Day License Request off-sale of liquor from the third-floor area once per week during organized tasting events restricted to the specific alcoholic beverages offered at the event. The Licensees were sworn in. Cropper stated that the Licensees previously appeared before the Board on February 18, 2026, seeking expanded off-sale privileges for both the first-floor retail area and year-round sales on the third floor. The application presented today is substantially different and more limited. The request today applies only to the third floor, once weekly, during special tasting events, and only for factory-sealed containers of the alcoholic beverages featured at the event. Cropper provided background on the property, noting the restaurant has operated at this location since 1945, predating zones, Health Department regulations, and the Board itself. The Taustin family has operated the business since the 1960s, maintaining one of the area's longest-standing restaurant operations. Cropper emphasized that the licensees have had no alcohol violations for more than 60 years, including during periods when the establishment operated as a nightclub. The facility has been fully rebuilt in recent years, with the restaurant now located on the third floor. Board Attorney Coates entered (Applicant's Exhibit #1), photograph of the screens replacing glass doors, and (Applicant's Exhibit #2), photograph proposed venue area. Cropper stated this is a fully enclosed event area designed for special events such as wine and liquor tastings and small private functions. Cole Taustin testified that he has been involved in operating Embers for his entire life and is now 40 years old. He received approval from the Ocean City Planning Commission for installation of sliding glass doors on the third floor. The remodeled space was intentionally built as a unique destination venue for downtown Ocean City. C. Taustin described two types of tasting events: Ticketed events requiring advance purchase; and Open-to-the-public events staffed by servers/bartenders who</p>								

WORCESTER COUNTY BOARD OF LICENSE COMMISSIONERS
 MINUTES FOR EMBERS RESTAURANT & BLU CRABHOUSE – LICENSE #18
 MAY 20, 2026

check identification, pour samples, and educate guests about the products. C. Taustin stated that guests frequently ask to purchase featured products at the event, but the business must currently refer them to local liquor stores, where specialty items are often difficult to locate. At past Board-approved special events, including a bourbon tasting, the product sold out with no incidents. C. Taustin testified that allowing limited off-sale during tasting events would serve customer needs and enhance the overall experience, not compete with Class “A” licensees. C. Taustin confirmed that purchases would be handled only by staff, packaged, and set aside for customer pickup upon departure. Bottles would not be sold outside of an active tasting event, and customers could not enter solely to purchase a bottle. The request is for one event per week. Jay Taustin testified that he has more than 60 years of experience in the food and beverage industry and has held multiple beverage licenses over his career. He has attended the tasting events, described them as successful, and agreed there is a public need for allowing customers to purchase the specialty products featured. He emphasized that the intent is not to compete with to-go licensees but to enhance the restaurant’s upscale branding and the customer experience. Several individuals appeared in opposition and were sworn in. Sara Humbury, owner of West O Bottle Shop, stated she believes Embers’ request would create competition with existing to-go businesses, particularly given that both restaurants and liquor stores may feature overlapping products at special events. She expressed concern that allowing one restaurant to have off-sale privileges for special events would set a precedent for others. Sam Ramadan, owner of Village Market Beer, Wine & Liquor expressed concerns that the request mirrors the February 18, 2026, application and would ultimately affect the viability of to-go liquor stores. He argued that restaurants should not have the same privileges as Class “A” licensees and feared that granting this request would open the door for similar applications from other restaurants. Ramadan referenced a prior agreement related to the sale of the former county liquor store property; Chairman Nichols clarified that the Board has no connection to such agreements. Richard Smith stated he is opposed to any additional off-sale privileges in the area, expressing concern that restaurants would each request weekly special events, effectively resulting in daily to-go sales county-wide. Jeff Walls, GM of 8th Street Liquors echoed the concerns about negative impacts on the shrinking market for to-go businesses. Commissioner Pusey asked the protestants whether the weekly events could increase interest in specialty products and thus benefit their liquor stores. Ramadan responded that to-go stores already conduct their own tastings and that restaurants entering this space would harm their businesses. Chairman Nichols clarified that this application is significantly different from the February 18th request. He noted that the Board’s role is not to regulate distribution, pricing, or market competition, but to evaluate license applications on their merit and ensure public safety and compliance. Chairman Nichols stated the Board has consistently acted to protect the marketplace and that the licensees’ testimony reflects substantial changes from the prior application. Commissioner Pusey questioned what happens to the alcohol that is left over from the special events. C. Taustin stated the leftover liquor from events are used in cocktails served on the premises and are not sold for off-premises consumption. He also reiterated that bottles could be taken home only during the special event and only for the products featured.

The Board approved the application for a Class “B” B/W/L 7 Day license request off-sale of liquor from the third-floor area once per week during organized tasting events restricted to the specific alcoholic beverages offered at the event.

Motion:	1st	Ms. Pusey	2nd	Mr. Nichols	Approved:	X	Yes	<input type="checkbox"/>	No
----------------	-----	-----------	-----	-------------	------------------	---	-----	--------------------------	----

Restrictions: OFF SALE OF LIQUOR FROM THIRD FLOOR AREA ONCE PER WEEK DURING ORGANIZED TASTING DINNER EVENTS RESTRICTED TO THE SPECIFIC ALCOHOLIC BEVERAGES OFFERED AT THE EVENT.

Time Hearing Ended: 2:11 p.m.

WORCESTER COUNTY BOARD OF LICENSE COMMISSIONERS
MINUTES FOR VIEW – LICENSE #954
MAY 20, 2026

Members Present:		R. Charles Nichols, Chairman		<input checked="" type="checkbox"/>	Marty W. Pusey	<input checked="" type="checkbox"/>	Reese Cropper, III	<input type="checkbox"/>
		Alternate Board Member: William E. Esham, III		<input type="checkbox"/>				
Staff Present:		April Payne, Administrator		<input checked="" type="checkbox"/>	Joe Pembroke, Inspector		<input checked="" type="checkbox"/>	
		Hank Fisher III, Esq., Board Attorney		<input type="checkbox"/>	Alternate Board Attorney: Name: Thomas Coates, Esq.		<input checked="" type="checkbox"/>	
		Stacey Odell, Administrative		<input checked="" type="checkbox"/>	Valarie Dawson, Court Reporter		<input checked="" type="checkbox"/>	
License #:	954	Hearing Date:	May 20, 2026		Hearing Start Time:	2:11 p.m.		
Class:	"B"	Type:	B/W/L		Day:	7 Day		
For: Cambria Liquor, LLC.		T/A: View		Address: 13 Saint Louis Avenue Ocean City, Maryland 21842				
New Application:	<input type="checkbox"/> Yes		Transfer:	<input type="checkbox"/> Yes		Meeting:	<input checked="" type="checkbox"/> Yes	
Violation:	<input type="checkbox"/> Yes							
Items to be discussed: Class "B" B/W/L 7 Day License request for live entertainment with a maximum of four pieces from 4 p.m. until 10:30 p.m. seven days per week.								
Applicants:	<input type="checkbox"/>		Licensees:	<input checked="" type="checkbox"/>		Representative:		
1. Anjeeb Shrestha			1. Joseph Moore, Esquire					
2.								
Witnesses:			Prototants:					
1. Tauhid Islam			1.					
Exhibits:			Exhibits					
1. Applicant's Collective Exhibit #1 – Photos of 1 st floor Dining Area, and Bar area			1.					
2. Applicant's Exhibit #2 – Photo - Music Location			2.					
3. Applicant's Exhibit #3 – Photos – Revision for entertainment area			3.					
<p>Hearing Minutes: Anjeeb Shrestha, and Tauhid Islam along with attorney Joseph Moore, Esquire appeared before the Board for a Class "B" B/W/L 7 Day license request for live entertainment with a maximum of four pieces from 4 p.m. until 10:30 p.m. seven days per week. The licensee was sworn in along with witness Tauhid Islam. Moore explained that the request concerns the bar and light dining area located on the first floor of the Cambria Hotel. Board Attorney Thomas Coates entered (Applicant's Collective Exhibit #1), Photographs of 1st floor, dining and bar area. The applicant is seeking approval for four-piece live entertainment in this space. Moore noted that this area is separate from other hotel venues and situated far enough away so as not to interfere with other hotel operations. Moore stated that Islam is a Managing Member of the LLC and confirmed that all information presented in the application is accurate. Islam agreed and confirmed that live entertainment in this designated space would not intrude into other areas of the hotel. Moore explained that the dance floor used for special events such as weddings is located on the far side of the hotel, and any use of entertainment in that area would require a separate request. Islam acknowledged this requirement. Chairman Nichols asked whether simultaneous entertainment or events would occur in multiple areas of the hotel at once. Islam stated "No," simultaneous events would not take place. Administrator April Payne asked for clarification on whether the live entertainment would be located behind the partition shown in the photographs. Moore stated "Yes," the entertainment would be behind the partition, although the original photo did not reflect this correctly. Chairman Nichols requested that the exhibits be corrected to show the proper entertainment location. Board Attorney</p>								

WORCESTER COUNTY BOARD OF LICENSE COMMISSIONERS
 MINUTES FOR VIEW – LICENSE #954
 MAY 20, 2026

Coates then entered (Applicant’s Exhibit #2), a photograph showing the corrected music location. Moore submitted additional revised photos, which Board Attorney Coates entered as (Applicant’s Exhibit #3), demonstrating that the entertainment area is located on the opposite side of the hotel venue. Moore stated the requested entertainment hours are 4:00 p.m. to 10:30 p.m. Islam explained that the music will be soft background music, intended to enhance the lobby environment. Guests may enjoy a glass of wine while listening. He also noted that the hotel setting requires that music not be too loud in consideration of overnight guests. Commissioner Pusey asked whether guests would be permitted to sit in the lobby area and listen to the music. Moore and Islam agreed that guests may sit in the lobby while music is playing. Chairman Nichols clarified that the request is for a four-piece group only and no disc jockey (DJ).

The Board approved the request for a Class “B” B/W/L 7 Day License for live entertainment with a maximum of four pieces from 4 p.m. until 10:30 p.m. seven days per week.

Motion:	1st	Ms. Pusey	2nd	Mr. Nichols	Approved:	X	Yes	<input type="checkbox"/>	No
----------------	-----	-----------	-----	-------------	------------------	---	-----	--------------------------	----

Restrictions: LIVE ENTERTAINMENT ALLOWED INSIDE WITH A MAXIMUM OF FOUR PIECES FROM 4 P.M. UNTIL 10:30 P.M., SEVEN DAYS PER WEEK IN THE RESTAURANT AND BAR AREA AS WELL AS THE EVENT ROOM AREA BUT NOT AT THE SAME TIME, DANCE FLOOR IS ALLOWED IN THE EVENT ROOM AREA ONLY, NO DISC JOCKEY ALLOWED.

Time Hearing Ended: 2:26 p.m.

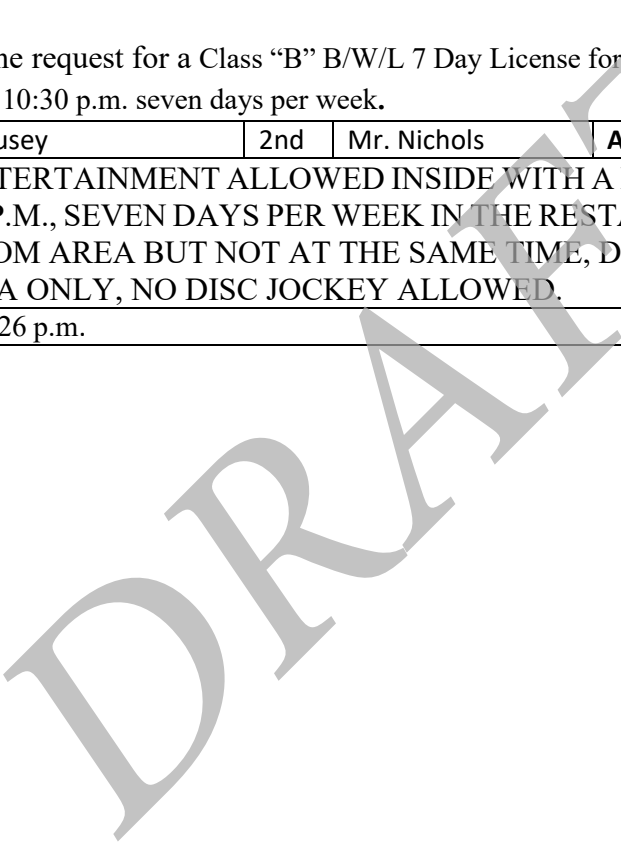

WORCESTER COUNTY BOARD OF LICENSE COMMISSIONERS
 MINUTES FOR BURLEY OAK BREWERY – LICENSE #770
 MAY 20, 2026

Members Present:		R. Charles Nichols, Chairman		<input checked="" type="checkbox"/>	Marty W. Pusey	<input checked="" type="checkbox"/>	Reese Cropper, III	<input type="checkbox"/>	
		Alternate Board Member: William E. Esham, III		<input type="checkbox"/>					
Staff Present:		April Payne, Administrator		<input checked="" type="checkbox"/>	Joe Pembroke, Inspector		<input checked="" type="checkbox"/>		
		Hank Fisher III, Esq., Board Attorney		<input type="checkbox"/>	Alternate Board Attorney: Name: Thomas Coates, Esq.		<input checked="" type="checkbox"/>		
		Stacey Odell, Administrative		<input checked="" type="checkbox"/>	Valarie Dawson, Court Reporter		<input checked="" type="checkbox"/>		
License #:	770	Hearing Date:	May 20, 2026		Hearing Start Time:	2:27 p.m.			
Class:	"D"	Type:	B/W/L		Day:	7 Day			
For: Burley Oak, LLC.		T/A: Burley Oak Brewery		Address: 10016 Old Ocean City Boulevard Berlin, Maryland 21811					
New Application:	<input type="checkbox"/> Yes		Transfer:	<input type="checkbox"/> Yes		Meeting:	<input checked="" type="checkbox"/> Yes		
Violation:	<input type="checkbox"/> Yes								
Items to be discussed: Class "D" B/W/L 7 Day License request for four games									
Applicants:	<input type="checkbox"/>		Licensees:	<input checked="" type="checkbox"/>		Representative:			
1. Bryan Brushmiller				1.					
Witnesses:				Protestants:					
1.				1.					
Exhibits:				Exhibits:					
1. Applicant's Exhibit #1 – Photo Location for Games				1.					
<p>Hearing Minutes: Licensee Bryan Brushmiller appeared before the Board for a Class "D" B/W/L 7 Day License request for four games. The licensee was sworn in. Brushmiller appeared before the Board requesting approval to install four arcade games at his licensed premises. He stated the games include two claw machines, one Golden Tee Golf game, and one Jurassic Park pinball machine. He explained that these additions are intended to improve customer experience, particularly for families, noting that children frequently use claw machines and that both children and adults enjoy pinball games. Board Attorney Thomas Coates entered (Applicant's Exhibit #1), photograph location for games. Commissioner Nichols confirmed that the claw machine shown in the photograph is one of the requested games. Brushmiller agreed and stated there will be two claw machines of the same type. He added that Golden Tee Golf is popular with the many golfers who visit the establishment, and pinball is currently a popular option for both adults and children. Commissioner Pusey clarified that the Brushmiller is requesting four total machines, consisting of three types of games, with two machines being identical claw machines. Brushmiller confirmed "Yes." Chairman Nichols stated that Applicant's Exhibit #1 must be updated to accurately show two claw machines.</p> <p>The Board approved the request for a Class "D" B/W/L 7 Day License request for four (4) arcade games.</p>									
Motion:	1st	Ms. Pusey		2nd	Mr. Nichols		Approved:	<input checked="" type="checkbox"/> Yes	<input type="checkbox"/> No
Restrictions: ONE GOLDEN TEE MACHINE ALLOWED, TWO CLAW MACHINES ALLOWED, ONE PIN BALL MACHINE ALLOWED.									
Time Hearing Ended: 2:31 p.m.									



Worcester County

BOARD OF LICENSE COMMISSIONERS

1:05 -

Application for Class "B" B/W/L 7 Day License
T/A: 2EZ Coastal Restaurant & Lounge
5401 Coastal Highway/Ocean City



**BOARD OF LICENSE COMMISSIONERS
FOR WORCESTER COUNTY
STAFF REPORT
NARRATIVE**

Type: *New Application*

Date: *5/21/2026*

License No: *N/A*

Class: *"B"*

Type: *Beer – Wine – Liquor 7 Day*

APPLICANT(S): 1. Ameerah A. Harris 2. Nathan Robert Richard Sample
 3. Nina Bianca Yli-Piipari 4.

TRADE NAME: *2EZ Coastal Restaurant and Lounge*

CORP: *2EZ Coastal Lounge LLC.*

LOCATION: *5401 Coastal Highway, Ocean City*

Restrictions: Live entertainment allowed inside with a maximum of four pieces non amplified from 4 p.m. until midnight five nights per week or live entertainment amplified allowed inside with a maximum of three pieces five nights per week until 9 p.m. non amplified and amplified cannot be at the same time, no outside live entertainment, no disc jockey allowed, outside speakers allowed from 11 a.m. until 10 pm., no games allowed, no pool tables allowed, no off sale

The restrictions above were listed for "Tequila Frogs" which was the previous licensed property at this location. The Resident Agent is Nina Bianca Yli-Piipari and she did obtain the signatures on the application. Nina B Yli-Piipari will hold ten percent of the LLC., Nathan Sample will hold 45 percent of the LLC., and Ameerah Harris will hold 45 percent of the LLC. The applicants have never held an alcoholic beverages license and therefore never had any violations involving alcohol.

Mr. Sample and Ms. Harris will manage the property. The inside measures 6000 sq. ft. The premises will have one bar with 15 stools. The left side of the premises will have five (5) booths with seating up to six (6), eight (8) tables with seating up to four (4) and three (3) tables for seating for two (2). The right side of the premises will have seven (7) high top tables for seating up to four (4) and four (4) tables for seating up to four (4). The outside deck/patio measures 600 sq. ft. and will have 13 tables with seating up to 50. The applicants currently do not request any live entertainment, D.J, games or off sale of alcoholic beverages. The operating hours of the premises will be 10 a.m. until 2 a.m., and the kitchen will close at 11 p.m. or 12 a.m.

The applicants will have an ID scanner and are TIPS/ TAM trained.

Joseph Pembroke
Liquor License Inspector

April Payne
Liquor License Administrator



Worcester County Board of License Commissioners
 New Application
 Class "B" B/W/L - 7 Day
 2EZ Coastal Restaurant & Lounge - License No. N/A
 Information & Technology - GIS Division - June 2026



NEW APPLICATION - 2EZ COASTAL RESTAURANT & LOUNGE

License No.	Class	License Type	Off Premise Sale	Business Name	Linear Distance (Feet)
915	B	BWL	N	2EZ COASTAL RESTAURANT & LOUNGE	0
124	B	BWL	N	PRINCESS BAYSIDE HOTEL	194
902	B	BWL	N	ALLEYOOPS MIDTOWN	469
34	A	BW	BW	ASSAWOMAN ALE SHOP	559
745	B	BWL	N	JOHNNY'S PIZZA	596
134	B	BWL	N	MACKY'S BAYSIDE BAR & GRILL	609
740	A	BW	BW	56TH STREET MARKET BEER AND WINE	629
89	B	BWL	N	QUALITY INN OCEANFRONT - ATRIUM BAR	630
813	B	BWL	N	BAD MONKEY	1216
274	A	BW	BW	7-11 STORE #23366	1339
516	C	BWL	N	OCEAN PINES BEACH CLUB	1556
219	B	BWL	N	FAGER'S ISLAND	1602
366	D	BWL	BWL	SEACRETS	1690
873	B	BWL	BWL	DRY 85 OC	1881
453	B	BWL	BW	SEA BAY CAFÉ	1946
864	B	BWL	N	DENNY'S RESTAURANT	2256
691	B	BWL	N	SATELLITE CAFÉ'	2271
852	H	BWL	N	RESIDENCE INN OF OCEAN CITY	2365
839	B	BWL	N	45TH STREET TAPHOUSE BAR AND GRILLE	2770
659	B	BWL	N	DEAD FREDDIE'S	2844



Front of 5401 Coastal Highway- second floor



Looking at the front entrance from the deck/patio



Looking from the top of the stairway at Coastal Highway South bound



Front Entrance looking to the left of the premises



Walking on the left side of the premises towards the back- Waiting area



Walking on the left side of the premises towards the back area.



Left side of the premises looking towards the back open area near the bathrooms



Left side of premises looking towards entrance from the back



Looking towards the bar area from the front entrance



Front of premises Bar area- Door # 2 leads to outside deck/patio area



Looking towards the right side of the premises from the bar area, door # 3 leads to outside deck/patio area



Looking from right side of premises towards the bar area



Looking to the right side back ok of the premises from the right side



Right side of premises looking to the back



Right side-back of the premises looking towards the front- Door #3 to outside patio/deck



Looking at the bar area from the right side of the premises



Looking from the stairs to the front entrance, door #2 and door #3 entrances to the premises.



Looking from the patio/deck towards Coastal Highway North



Looking towards Coastal Highway from the deck/patio area.

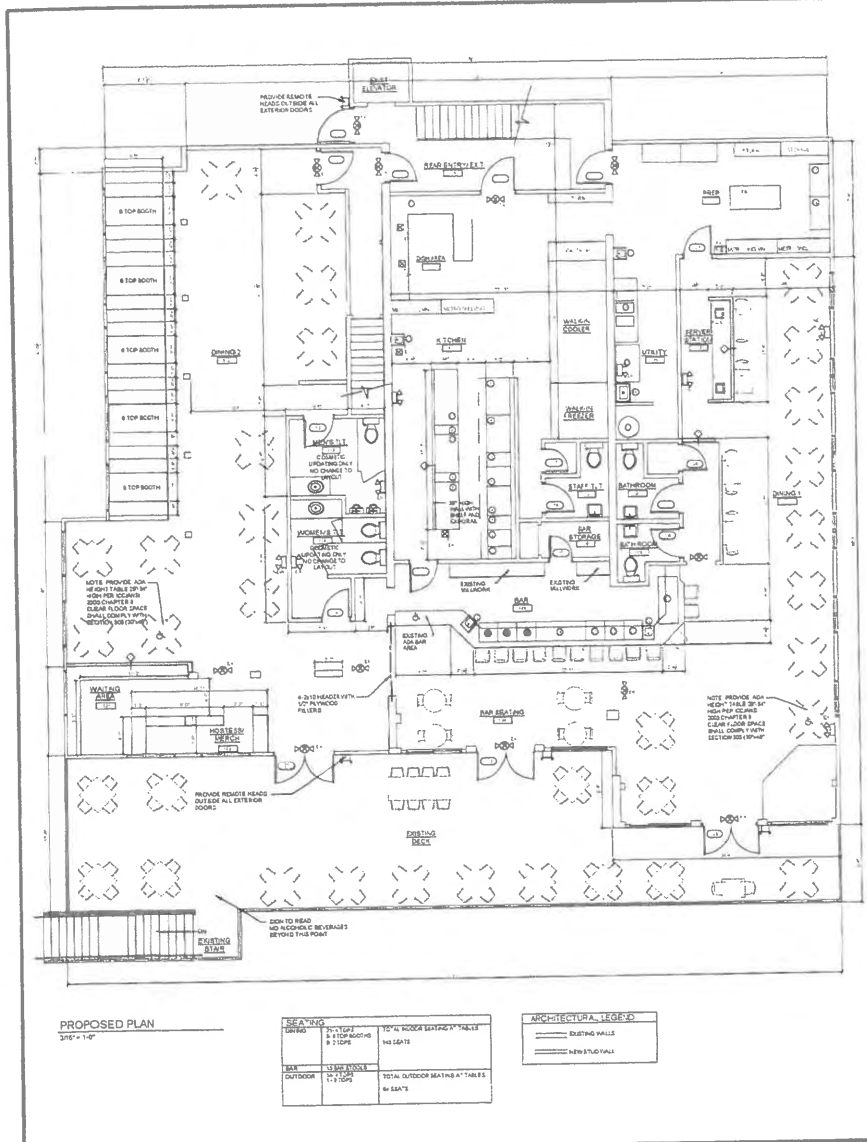

DOOR NO.	DOOR TYPE	DOOR FRAME	MATERIAL	FINISH	DOOR WEIGHT	DOOR RATING	DOOR SWING	KEY NOTES
1	SW	1 1/2\"/>						

KEYED DOOR NOTES

1. TO OPEN THIS DOOR THE HANDLE MUST BE IN THE UP POSITION. REPLACE AS REQUIRED. ALL DOORS NOT MEETING REQUIREMENTS WILL BE REPAIRED TO CODE REQUIRED STANDARDS. PROVIDE MAGNETIC KEYS TO KEEP DOORS OPEN AND CLOSED IN PLACE OF KEY.

GENERAL DOOR NOTES

1. ALL HARDWARE SHALL COMPLY WITH APPLICABLE ACCESS AND EGRESS REQUIREMENTS. REPLACE AS NECESSARY.
2. PROVIDE 1\"/>

NO.	EQUIPMENT	QUANTITY	MANUFACTURER	MODEL	NOTES
1	SE FRYER	1	LOGAN	1000	
2	GRIDDLE	1	LOGAN	1000	
3	STOVE	1	LOGAN	1000	
4	COFFEE DISPENSER	1	LOGAN	1000	
5	ICE CREAM MAKER	1	LOGAN	1000	
6	ICE CREAM DISPENSER	1	LOGAN	1000	
7	ICE CREAM DISPENSER	1	LOGAN	1000	
8	ICE CREAM DISPENSER	1	LOGAN	1000	
9	ICE CREAM DISPENSER	1	LOGAN	1000	
10	ICE CREAM DISPENSER	1	LOGAN	1000	
11	ICE CREAM DISPENSER	1	LOGAN	1000	
12	ICE CREAM DISPENSER	1	LOGAN	1000	
13	ICE CREAM DISPENSER	1	LOGAN	1000	
14	ICE CREAM DISPENSER	1	LOGAN	1000	
15	ICE CREAM DISPENSER	1	LOGAN	1000	
16	ICE CREAM DISPENSER	1	LOGAN	1000	
17	ICE CREAM DISPENSER	1	LOGAN	1000	
18	ICE CREAM DISPENSER	1	LOGAN	1000	
19	ICE CREAM DISPENSER	1	LOGAN	1000	
20	ICE CREAM DISPENSER	1	LOGAN	1000	
21	ICE CREAM DISPENSER	1	LOGAN	1000	
22	ICE CREAM DISPENSER	1	LOGAN	1000	
23	ICE CREAM DISPENSER	1	LOGAN	1000	
24	ICE CREAM DISPENSER	1	LOGAN	1000	
25	ICE CREAM DISPENSER	1	LOGAN	1000	

WALL TYPES

1. INTERIOR FINISHES ON WALLS AND CEILING TO MEET MINIMUM REQUIREMENTS OF CLASS A OR C FLAME PROPAGATION INDEX IN ACCORDANCE WITH NFPA 101. PROVIDE SMOKE AND HEAT RESISTANT GLASS IN KITCHEN AND BATHROOMS TO BE WASHABLE AND SELF-CLEANING.

2. ALL PAINTED SURFACES TO HAVE 1 COAT PRIMER AND 2 COATS FINISH PAINT. COLOR TO BE SELECTED BY OWNER.

3. ALL TRIM PAINT TO BE 2 COATS ALL VERTICAL LOCATIONS TO BE FINISHED WITH PUTTY.

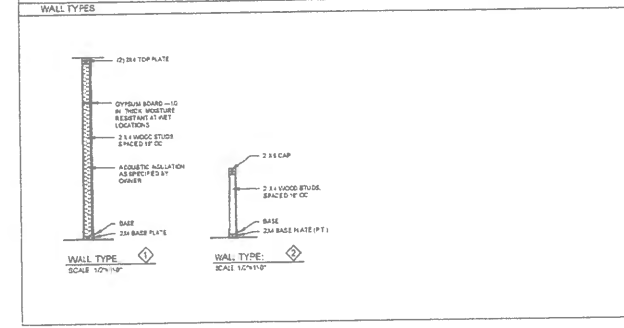

WALL TYPE
SCALE 1/2\"/>

D
 ARCHT
 13
 DWG
 AN
 25
 100

2EZ

COASTAL

RESTAURANT • LOUNGE

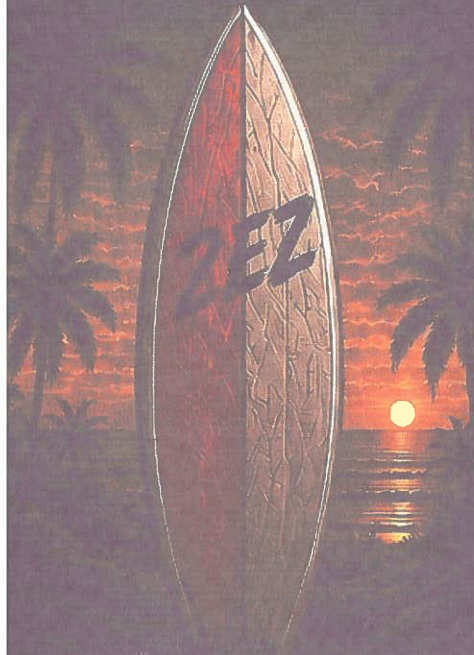

GOOD FOOD
GOOD PEOPLE
GOOD VIBES
COASTAL SOUL

APPETIZERS

- SEAFOOD POTATO SKINS \$11
Crispy potato skins loaded with crab, shrimp, melted cheese, sour cream & scallions
- COASTAL WINGS \$11
Honey Old Bay • BBQ
Hot (Mild or Spicy)
Korean BBQ • 2EZ Sauce
- CORN NUGGETS \$8
Crispy corn nuggets served with spicy ranch

SOUPS

- CREAM OF CRAB \$7
Rich, creamy & packed with lump crab

Craft Your Plate

Crinkle cut fries or baked potato with melted cheese & 2EZ drizzle

ADD PROTEIN

Chicken • Cheesesteak • Shrimp +2 • Salmon +5

ENHANCE YOUR PLATE

- Crab +6 Ranch +1
- Shrimp +2 Fried Onions +1
- Bacon +2 Extra Cheese +2

HANDHELDS

- BIG TEXAS BURGER \$14
BBQ, bacon, Cooper sharp, fried onions
- CRABBY BURGER \$15
Double smash, crab dip, Cooper sharp
- PHILLY \$14
Steak, onions, peppers, Cooper Sharp on a toasted hoagie roll

Make it yours:

Tomato • Lettuce • Fried Onions
Mayo • Hot Peppers

COASTAL SALADS

- BUILD YOUR OWN SALAD \$11
Mixed greens, tomatoes, cucumbers, cheese
- ADD PROTEIN:
Chicken +3 • Shrimp +4 • Salmon +6

EZ TACOS

- PHILLY BOY (3) \$13
Cheesesteak, cheese, soft tortilla
- BOOM BOOM SHRIMP (3) \$14
Grilled or fried shrimp, boom boom sauce
- CHICKEN PHILLY (3) \$13
Grilled chicken, cheese, soft tortilla
- 2EZ SNACK WRAP (3) \$12

SIGNATURE MAINS

- SALMON CRAB CREAM PLATE \$25
Grilled salmon, creamy crab & shrimp sauce
- GARLIC HONEY SALMON \$25
Grilled salmon in garlic honey glaze
- GARLIC HONEY CHICKEN \$19
Fried or grilled chicken in garlic honey glaze
- LAMB CHOPS \$25
Sweet & spicy teriyaki glaze
- JUMBO FRIED SHRIMP \$19
Crispy shrimp with house sauce

SIDES

- FRIES (CRINKLE CUT)..... \$4
- YAMS \$5
- MAC & CHEESE \$5
- VEGETABLES \$5

Available as add-on to any item.

302-331-5995

Business Phone No.

Received 5-15-26
APP

WORCESTER COUNTY
STATE OF MARYLAND

ALCOHOLIC BEVERAGES LAW ^{7 Day}
APPLICATION FOR A CLASS "B" Beer, Wine, Liquor LICENSE
"NEW APPLICATION"

For the use of:

(Check one) An Individual Partnership Corporation Unincorporated Association Limited Liability Co.

To the Board of License Commissioners Worcester County.

Date May 5th, 2026

Application is made by the undersigned under the provisions of Article 2B of the Annotated Code of Maryland, as amended, title "Alcoholic Beverages," for the above license, and the applicant(s) submit(s) and certify(ies) to the following information required by the Article.

Fill in all the blanks:

Applications will NOT be accepted without all Applicant information, including middle name.

- Applicant(s)
 - Full Name Ameerah Aiyann Harris Residence [Redacted]
 Date of Birth [Redacted] Period of Residence 2 years in Wor. County [Redacted]
 Place of Birth [Redacted] Naturalized at N/A Year N/A
 Telephone Number [Redacted] Race African American Sex Female
 - Full Name Natethan Robert Richard Sample Residence [Redacted]
 Date of Birth [Redacted] Period of Residence 12 years in Wor. County [Redacted]
 Place of Birth [Redacted] Naturalized at N/A Year N/A
 Telephone Number [Redacted] Race Biracial Sex M
 - Full Name Nina Blanca Yli-Piipari Residence [Redacted]
 Date of Birth [Redacted] Period of Residence 11 yrs in Wor. County 11 yrs
 Place of Birth [Redacted] Naturalized at N/A Year [Redacted]
 Telephone Number [Redacted] Race White Sex F

2. The applicant(s) is/are citizen(s) of the United States, and (if the application is for an individual or a partnership), has/have been for two years next preceding the filing of this application (a) resident(s) of Worcester County. The applicant(s) (if applying as a qualifying individual for a corporation) is a registered voter and taxpayer in Worcester County and shall also have resided there for at least two years prior to the filing of this application. The applicant(s) thus qualified is/are: 1() 2() 3() (Check number to correspond with name(s) listed above.)

*3. State the Retail Sales Tax No.: 2EZ Coastal Lounge, LLC

4. If a corporation, state corporate name and trade name, if any: 2EZ Coastal Lounge LLC
If other than a corporation, state trade name to be used: 2EZ Coastal Restaurant and Lounge

5. Address of place to be licensed (Give street number or accurate description): 5401 Coastal Highway Ocean City, Maryland 21842 *add Tequila Frogs location*

- Nearest intersecting street: 54 Street + Approximate distance: 50 feet
- Tax District where located: 10th Is this an application for a new license? Yes
- Is this a transfer from a present licensee? No From Whom? _____

(This Board must be furnished releases by the State Comptroller's Office approving the bulk sales transfer and clearing all tax accounts before any license will be transferred.)

D. Are you represented by an attorney? Whom: Dick Widdowson Tel. No.: 410-546-0050
Address: 312 main Street South #A Salisbury, Maryland 21801

E. Describe premises to be licensed: Restaurant with bar and full service kitchen
F. If this is a new or proposed building or a building not previously licensed, a copy of the bona fide plans must be filed with this application or presented at the time of the hearing.

6. State name and address of owner of record of premises: Robert Riccio Sr.
5401 Coastal Hwy Ocean City, MD 21842

7. Have you ever been: [REDACTED] [REDACTED] [REDACTED]
A. Convicted of a misdemeanor? 1 [REDACTED] 2 [REDACTED] 3 [REDACTED]

B. Adjudged guilty of violating alcoholic beverage laws by a court, administrative agency or Board of License Commissioners?
1 NO 2 NO 3 NO

C. Adjudged guilty of violating gambling laws? 1 NO 2 NO 3 NO
D. Adjudged guilty of any offense against the laws of the United States? 1 NO 2 NO 3 NO

If so, when and where: N/A

E. Convicted of a felony or offered a plea of nolo contendere to a felony indictment and charge was subsequently accepted by a court?
1 NO 2 NO 3 NO

8. A. Have you ever held a license for the sale of alcoholic beverages? 1 NO 2 NO 3 NO
If yes, state when and where: N/A

B. If so, has such license been suspended or revoked? 1 N/A 2 N/A 3 N/A
If answer is yes, give full details: N/A

C. If so, were you ever found in violation of any alcoholic beverage law? 1 N/A 2 N/A 3 N/A

9. Have you ever applied for an alcoholic beverage license in the State of Maryland? 1 NO 2 NO 3 NO
If answer is yes, state when and where: N/A

10. What financial interests do you have in the business to be conducted under this license?
1 45% 2 45% 3 10%

11. Are you financially interested in any other alcoholic beverage business for which a license has been applied for, granted or issued?
1 NO 2 NO 3 NO

If so, give details: N/A

12. Is your wife or husband, as the case may be, a licensee and does her or she have any financial interest in any other alcoholic beverage business in the State of Maryland? 1 NO 2 NO 3 NO

If so, give details: N/A

13. Is there now, or will there be, during the continuance of the license applied for, any other person financially interested in said license or the business to be conducted thereunder? 1 NO 2 NO 3 NO

If so, state name, address, telephone no., age, percent of interest and state whether or not an interest is held in any other alcoholic beverage license: N/A

14. A. Does any manufacturer, brewer, distiller or wholesaler have any financial interest in the premises or business to be conducted under this license? NO

B. Will any such interest be hereafter conveyed or granted to any such manufacturer, brewer, distiller or wholesaler?
NO

15. Do you now have, or will you hereafter have, any indebtedness or other financial indebtedness, directly or indirectly, to any manufacturer, brewer, distiller or wholesaler, other than for purchase of alcoholic beverage? NO

16. A. If granted a license, will you conform to all laws and regulations relating to the business in which you propose to engage?
Yes

B. If granted a license, will you agree to keep current all state and local tax obligations including, but not limited to, state sales and use tax, withholding tax and admissions tax?
Yes

I/We consent to the Board of License Commissioners being furnished with a copy of my/our arrest record, if any, by any state, local or federal law enforcement or judicial agency. App. #1 Yes App. #2 Yes App. #3 Yes

LIMITED LIABILITY MEMBERSHIP AFFIDAVIT

Ameerah A Harris
Name

[Redacted]

2 years
Period of Residence

[Redacted]

[Redacted]
Office Telephone No.

[Redacted]
Date of Birth

Choose Sex

[Redacted]
Place of Birth

[Redacted]
Social Security No.

Naturalized Yes () No (x)

N/A
Where Naturalized

Petition No.

Munch Junky Eatery
Place of Employment

205 Sunrise Ave, Ridgely, MD 21060
Address of Employer

4 years
Length of Employment

1b. What is your ownership interest in LLC?

45%
Percent of Ownership

2b. What is your capital contribution to LLC?

\$100,000

2. Have you ever been convicted of a felony, or have you been adjudged guilty of violating the laws governing the sale of any alcoholic beverages or for the prevention of gambling in the State of Maryland or adjudged guilty of any offense against the United States laws?

Yes () No (x) If yes, please detail.

3. State whether you have had a license for the sale of alcoholic beverages denied or revoked.

Yes () No (x) If yes, please detail.

4. Have you ever held a license for the sale of alcoholic beverages and if so in what State and what location?

No

5. Are you financially interested in any other place of business that has an alcoholic beverage license in the State of Maryland?

Yes () No (x) If yes, please detail.

6. As a member, how much time will you spend on the licensed premises?

Full time Operational Oversight

7. What profit will you derive in proportion to the percentage of ownership?

45%

8. As a member have you read the Rules and Regulations of the Board?

Yes (x) No ()

9. If you are a qualified Resident Agent, are you a Worcester County, Maryland

resident? Yes () No (x)

PROVIDE COPY(ies) OF ANY AND ALL AGREEMENTS / CONTRACTS relative to the operation of the business to be conducted under the alcoholic beverage license. (Inclusive of managerial agreements and/or sales contracts.)

Ameerah A Harris
Signature of Member

I HEREBY CERTIFY THAT BEFORE ME, a Notary Public in and for the State of Maryland, County of Worcester, personally appeared Ameerah A. Harris In said County and State on this 14th day of May, 2026, and made oath in due form of law that the matters and facts in the foregoing Affidavit are true and that they would in fact comply with all statements made therein.

WITNESS my hand and official Seal this 14th day of May, 2026

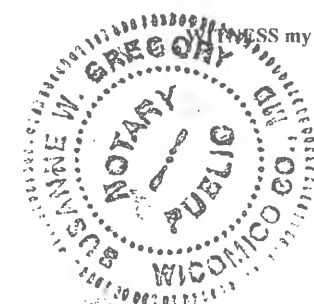

Susanna W. Gregory
Notary Public

My Commission Expires: 1-17-2030

LIMITED LIABILITY MEMBERSHIP AFFIDAVIT

Name: Nathan R Sample Residence Address: [Redacted] Zip Code: [Redacted]
12 Years
[Redacted] Office Telephone No. [Redacted]
[Redacted] Date of Birth [Redacted] Sex [Redacted] Place of Birth [Redacted] Social Security No. [Redacted]

Naturalized Yes () No (X) NIA Where Naturalized _____ Petition No. _____

Place of Employment: Easter Seals
100 Enterprise Pl # Dover, DE 19904 Address of Employer Length of Employment: 1yr

1b. What is your ownership interest in LLC? 45% Percent of Ownership
2b. What is your capital contribution to LLC? \$100,000

2. Have you ever been convicted of a felony, or have you been adjudged guilty of violating the laws governing the sale of any alcoholic beverages or for the prevention of gambling in the State of Maryland or adjudged guilty of any offense against the United States laws?
Yes () No (X) If yes, please detail. _____

3. State whether you have had a license for the sale of alcoholic beverages denied or revoked.
Yes () No (X) If yes, please detail. _____

4. Have you ever held a license for the sale of alcoholic beverages and if so in what State and what location?
No

5. Are you financially interested in any other place of business that has an alcoholic beverage license in the State of Maryland?
Yes () No (X) If yes, please detail. _____

As a member, how much time will you spend on the licensed premises?
Full time Operational Oversight

7. What profit will you derive in proportion to the percentage of ownership?
45%

8. As a member have you read the Rules and Regulations of the Board?
Yes (X) No ()

9. If you are a qualified Resident Agent, are you a Worcester County, Maryland resident? Yes () No (X)

PROVIDE COPY(ies) OF ANY AND ALL AGREEMENTS / CONTRACTS relative to the operation of the business to be conducted under the alcoholic beverage license. (Inclusive of managerial agreements and/or sales contracts.)

[Signature]
Signature of Member

I HEREBY CERTIFY THAT BEFORE ME, a Notary Public in and for the State of Maryland, County of Wicomico, personally appeared Nathan R. Sample In said County and State on this 14th day of May, 2026, and made oath in due form of law that the matters and facts in the foregoing Affidavit are true and that they would in fact comply with all statements made therein.

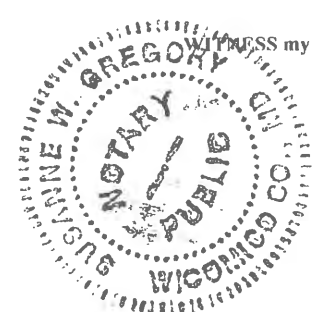

WITNESS my hand and official Seal this 14th day of May, 2026
Susanne W. Gregory
Notary Public
My Commission Expires: 1-17-2030

LIMITED LIABILITY MEMBERSHIP AFFIDAVIT

Name: Nina Bianca Yli-Piipari
Residence Address: [Redacted]
Zip Code: [Redacted]
Date of Birth: 11 years
Home Telephone No.: [Redacted]
Office Telephone No.: [Redacted]
Social Security No.: [Redacted]

Naturalized Yes () No () N/A
Where Naturalized: N/A
Petition No.:

Place of Employment: Piedmont Airlines, Inc
Address of Employer: 5413 Airport Terminal Rd, Salisbury
Length of Employment: 18 years

1b. What is your ownership interest in LLC? 10%
2b. What is your capital contribution to LLC? 0%

2. Have you ever been convicted of a felony, or have you been adjudged guilty of violating the laws governing the sale of any alcoholic beverages or for the prevention of gambling in the State of Maryland or adjudged guilty of any offense against the United States laws?

Yes () No () If yes, please detail.

3. State whether you have had a license for the sale of alcoholic beverages denied or revoked.
Yes () No () If yes, please detail.

4. Have you ever held a license for the sale of alcoholic beverages and if so in what State and what location?
N/A

5. Are you financially interested in any other place of business that has an alcoholic beverage license in the State of Maryland?

Yes () No () If yes, please detail.

As a member, how much time will you spend on the licensed premises?

Part time

7. What profit will you derive in proportion to the percentage of ownership?

10%

8. As a member have you read the Rules and Regulations of the Board?

Yes () No ()

9. If you are a qualified Resident Agent, are you a Worcester County, Maryland

resident? Yes () No ()

PROVIDE COPY(ies) OF ANY AND ALL AGREEMENTS / CONTRACTS relative to the operation of the business to be conducted under the alcoholic beverage license (Inclusive of managerial agreements and/or sales contracts.)

Signature of Member: [Handwritten Signature]

I HEREBY CERTIFY THAT BEFORE ME, a Notary Public in and for the State of Maryland, County of Worcester, personally appeared Nina Bianca Yli-Piipari In said County and State on this 14th day of May, 2026, and made oath in due form of law that the matters and facts in the foregoing Affidavit are true and that they would in fact comply with all statements made therein.

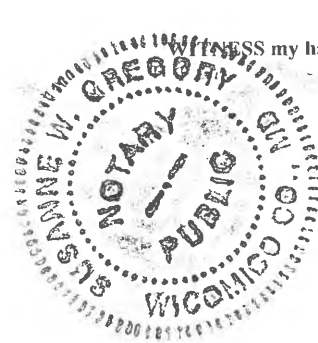

WITNESS my hand and official Seal this 14th day of May, 2026
Susanne W. Gregory
Notary Public

My Commission Expires: 1-17-2030

Privacy Act Statement

Authority: The FBI's acquisition, preservation, and exchange of fingerprints and associated information is generally authorized under 28 U.S.C. 534. Depending on the nature of your application, supplemental authorities include Federal statutes, State statutes pursuant to Pub. L. 92-544, Presidential Executive Orders, and federal regulations. Providing your fingerprints and associated information is voluntary; however, failure to do so may affect completion or approval of your application.

Principal Purpose: Certain determinations, such as employment, licensing, and security clearances, may be predicated on fingerprint-based background checks. Your fingerprints and associated information/biometrics may be provided to the employing, investigating, or otherwise responsible agency, and/or the FBI for the purpose of comparing your fingerprints to other fingerprints in the FBI's Next Generation Identification (NGI) system or its successor systems (including civil, criminal, and latent fingerprint repositories) or other available records of the employing, investigating, or otherwise responsible agency. The FBI may retain your fingerprints and associated information/biometrics in NGI after the completion of this application and, while retained, your fingerprints may continue to be compared against other fingerprints submitted to or retained by NGI.

Routine Uses: During the processing of this application and for as long thereafter as your fingerprints and associated information/biometrics are retained in NGI, your information may be disclosed pursuant to your consent, and may be disclosed without your consent as permitted by the Privacy Act of 1974 and all applicable Routine Uses as may be published at any time in the Federal Register, including the Routine Uses for the NGI system and the FBI's Blanket Routine Uses. Routine uses include, but are not limited to, disclosures to: employing, governmental or authorized non-governmental agencies responsible for employment, contracting, licensing, security clearances, and other suitability determinations; local, state, tribal, or federal law enforcement agencies; criminal justice agencies; and agencies responsible for national security or public safety.

As of 03/30/2018

NONCRIMINAL JUSTICE APPLICANT'S PRIVACY RIGHTS

As an applicant who is the subject of a national fingerprint-based criminal history record check for a noncriminal justice purpose (such as an application for employment or a license, an immigration or naturalization matter, security clearance, or adoption), you have certain rights which are discussed below. All notices must be provided to you in writing.¹ These obligations are pursuant to the Privacy Act of 1974, Title 5, United States Code (U.S.C.) Section 552a, and Title 28 Code of Federal Regulations (CFR), 50.12, among other authorities.

- You must be provided an adequate written FBI Privacy Act Statement (dated 2013 or later) when you submit your fingerprints and associated personal information. This Privacy Act Statement must explain the authority for collecting your fingerprints and associated information and whether your fingerprints and associated information will be searched, shared, or retained.²
- You must be advised in writing of the procedures for obtaining a change, correction, or update of your FBI criminal history record as set forth at 28 CFR 16.34.
- You must be provided the opportunity to complete or challenge the accuracy of the information in your FBI criminal history record (if you have such a record).
- If you have a criminal history record, you should be afforded a reasonable amount of time to correct or complete the record (or decline to do so) before the officials deny you the employment, license, or other benefit based on information in the FBI criminal history record.
- If agency policy permits, the officials may provide you with a copy of your FBI criminal history record for review and possible challenge. If agency policy does not permit it to provide you a copy of the record, you may obtain a copy of the record by submitting fingerprints and a fee to the FBI. Information regarding this process may be obtained at <https://www.fbi.gov/services/cjis/identity-history-summary-checks> and <https://www.edo.cjis.gov>.
- If you decide to challenge the accuracy or completeness of your FBI criminal history record, you should send your challenge to the agency that contributed the questioned information to the FBI. Alternatively, you may send your challenge directly to the FBI by submitting a request via <https://www.edo.cjis.gov>. The FBI will then forward your challenge to the agency that contributed the questioned information and request the agency to verify or correct the challenged entry. Upon receipt of an official communication from that agency, the FBI will make any necessary changes/corrections to your record in accordance with the information supplied by that agency. (See 28 CFR 16.30 through 16.34.)
- You have the right to expect that officials receiving the results of the criminal history record check will use it only for authorized purposes and will not retain or disseminate it in violation of federal statute, regulation or executive order, or rule, procedure or standard established by the National Crime Prevention and Privacy Compact Council.³

Updated 11/6/2019

I acknowledge receipt of the FBI Privacy Act Statement and Noncriminal Justice Applicant's Privacy Rights.

Ameerah Aijana Harris
Print Name

Ameerah Aijana Harris
Signature

May 1st, 2026
Date

¹ Written notification includes electronic notification, but excludes oral notification. ² <https://www.fbi.gov/services/cjis/compact-council/privacy-act-statement>
³ See 5 U.S.C. 552a(b); 28 U.S.C. 534(b); 34 U.S.C. § 40316 (formerly cited as 42 U.S.C. § 14616), Article IV(c); 28 CFR 20.21(c), 20.33(d) and 906.2(d).

- **Privacy Act Statement**

Authority: The FBI's acquisition, preservation, and exchange of fingerprints and associated information is generally authorized under 28 U.S.C. 534. Depending on the nature of your application, supplemental authorities include Federal statutes, State statutes pursuant to Pub. L. 92-544, Presidential Executive Orders, and federal regulations. Providing your fingerprints and associated information is voluntary; however, failure to do so may affect completion or approval of your application.

Principal Purpose: Certain determinations, such as employment, licensing, and security clearances, may be predicated on fingerprint-based background checks. Your fingerprints and associated information/biometrics may be provided to the employing, investigating, or otherwise responsible agency, and/or the FBI for the purpose of comparing your fingerprints to other fingerprints in the FBI's Next Generation Identification (NGI) system or its successor systems (including civil, criminal, and latent fingerprint repositories) or other available records of the employing, investigating, or otherwise responsible agency. The FBI may retain your fingerprints and associated information/biometrics in NGI after the completion of this application and, while retained, your fingerprints may continue to be compared against other fingerprints submitted to or retained by NGI.

Routine Uses: During the processing of this application and for as long thereafter as your fingerprints and associated information/biometrics are retained in NGI, your information may be disclosed pursuant to your consent, and may be disclosed without your consent as permitted by the Privacy Act of 1974 and all applicable Routine Uses as may be published at any time in the Federal Register, including the Routine Uses for the NGI system and the FBI's Blanket Routine Uses. Routine uses include, but are not limited to, disclosures to: employing, governmental or authorized non-governmental agencies responsible for employment, contracting, licensing, security clearances, and other suitability determinations; local, state, tribal, or federal law enforcement agencies; criminal justice agencies; and agencies responsible for national security or public safety.

As of 03/30/2018

NONCRIMINAL JUSTICE APPLICANT'S PRIVACY RIGHTS

As an applicant who is the subject of a national fingerprint-based criminal history record check for a noncriminal justice purpose (such as an application for employment or a license, an immigration or naturalization matter, security clearance, or adoption), you have certain rights which are discussed below. All notices must be provided to you in writing.¹ These obligations are pursuant to the Privacy Act of 1974, Title 5, United States Code (U.S.C.) Section 552a, and Title 28 Code of Federal Regulations (CFR), 50.12, among other authorities.

- You must be provided an adequate written FBI Privacy Act Statement (dated 2013 or later) when you submit your fingerprints and associated personal information. This Privacy Act Statement must explain the authority for collecting your fingerprints and associated information and whether your fingerprints and associated information will be searched, shared, or retained.²
- You must be advised in writing of the procedures for obtaining a change, correction, or update of your FBI criminal history record as set forth at 28 CFR 16.34.
- You must be provided the opportunity to complete or challenge the accuracy of the information in your FBI criminal history record (if you have such a record).
- If you have a criminal history record, you should be afforded a reasonable amount of time to correct or complete the record (or decline to do so) before the officials deny you the employment, license, or other benefit based on information in the FBI criminal history record.
- If agency policy permits, the officials may provide you with a copy of your FBI criminal history record for review and possible challenge. If agency policy does not permit it to provide you a copy of the record, you may obtain a copy of the record by submitting fingerprints and a fee to the FBI. Information regarding this process may be obtained at <https://www.fbi.gov/services/cjis/identity-history-summary-checks> and <https://www.edo.cjis.gov>.
- If you decide to challenge the accuracy or completeness of your FBI criminal history record, you should send your challenge to the agency that contributed the questioned information to the FBI. Alternatively, you may send your challenge directly to the FBI by submitting a request via <https://www.edo.cjis.gov>. The FBI will then forward your challenge to the agency that contributed the questioned information and request the agency to verify or correct the challenged entry. Upon receipt of an official communication from that agency, the FBI will make any necessary changes/corrections to your record in accordance with the information supplied by that agency. (See 28 CFR 16.30 through 16.34.)
- You have the right to expect that officials receiving the results of the criminal history record check will use it only for authorized purposes and will not retain or disseminate it in violation of federal statute, regulation or executive order, or rule, procedure or standard established by the National Crime Prevention and Privacy Compact Council.³

Updated 11/6/2019

I acknowledge receipt of the FBI Privacy Act Statement and Noncriminal Justice Applicant's Privacy Rights.

Ngtehan Sample
Print Name

Signature

5-1-2026
Date

¹ Written notification includes electronic notification, but excludes oral notification. ² <https://www.fbi.gov/services/cjis/compact-council/privacy-act-statement>
³ Sec 5 U.S.C. 552a(b); 28 U.S.C. 534(b); 34 U.S.C. § 40316 (formerly cited as 42 U.S.C. § 14616), Article IV(c); 28 CFR 20.21(c), 20.33(d) and 906.2(d).

Privacy Act Statement

Authority: The FBI's acquisition, preservation, and exchange of fingerprints and associated information is generally authorized under 28 U.S.C. 534. Depending on the nature of your application, supplemental authorities include Federal statutes, State statutes pursuant to Pub. L. 92-544, Presidential Executive Orders, and federal regulations. Providing your fingerprints and associated information is voluntary; however, failure to do so may affect completion or approval of your application.

Principal Purpose: Certain determinations, such as employment, licensing, and security clearances, may be predicated on fingerprint-based background checks. Your fingerprints and associated information/biometrics may be provided to the employing, investigating, or otherwise responsible agency, and/or the FBI for the purpose of comparing your fingerprints to other fingerprints in the FBI's Next Generation Identification (NGI) system or its successor systems (including civil, criminal, and latent fingerprint repositories) or other available records of the employing, investigating, or otherwise responsible agency. The FBI may retain your fingerprints and associated information biometrics in NGI after the completion of this application and, while retained, your fingerprints may continue to be compared against other fingerprints submitted to or retained by NGI.

Routine Uses: During the processing of this application and for as long thereafter as your fingerprints and associated information/biometrics are retained in NGI, your information may be disclosed pursuant to your consent, and may be disclosed without your consent as permitted by the Privacy Act of 1974 and all applicable Routine Uses as may be published at any time in the Federal Register, including the Routine Uses for the NGI system and the FBI's Blanket Routine Uses. Routine uses include, but are not limited to, disclosures to: employing, governmental or authorized non-governmental agencies responsible for employment, contracting, licensing, security clearances, and other suitability determinations; local, state, tribal, or federal law enforcement agencies; criminal justice agencies; and agencies responsible for national security or public safety.

As of 03/30/2018

NONCRIMINAL JUSTICE APPLICANT'S PRIVACY RIGHTS

As an applicant who is the subject of a national fingerprint-based criminal history record check for a noncriminal justice purpose (such as an application for employment or a license, an immigration or naturalization matter, security clearance, or adoption), you have certain rights which are discussed below. All notices must be provided to you in writing.¹ These obligations are pursuant to the Privacy Act of 1974, Title 5, United States Code (U.S.C.) Section 552a, and Title 28 Code of Federal Regulations (CFR), 50.12, among other authorities.

- You must be provided an adequate written FBI Privacy Act Statement (dated 2013 or later) when you submit your fingerprints and associated personal information. This Privacy Act Statement must explain the authority for collecting your fingerprints and associated information and whether your fingerprints and associated information will be searched, shared, or retained.²
- You must be advised in writing of the procedures for obtaining a change, correction, or update of your FBI criminal history record as set forth at 28 CFR 16.34.
- You must be provided the opportunity to complete or challenge the accuracy of the information in your FBI criminal history record (if you have such a record).
- If you have a criminal history record, you should be afforded a reasonable amount of time to correct or complete the record (or decline to do so) before the officials deny you the employment, license, or other benefit based on information in the FBI criminal history record.
- If agency policy permits, the officials may provide you with a copy of your FBI criminal history record for review and possible challenge. If agency policy does not permit it to provide you a copy of the record, you may obtain a copy of the record by submitting fingerprints and a fee to the FBI. Information regarding this process may be obtained at <https://www.fbi.gov/services/cjis/identity-history-summary-checks> and <https://www.edo.cjis.gov>.
- If you decide to challenge the accuracy or completeness of your FBI criminal history record, you should send your challenge to the agency that contributed the questioned information to the FBI. Alternatively, you may send your challenge directly to the FBI by submitting a request via <https://www.edo.cjis.gov>. The FBI will then forward your challenge to the agency that contributed the questioned information and request the agency to verify or correct the challenged entry. Upon receipt of an official communication from that agency, the FBI will make any necessary changes/corrections to your record in accordance with the information supplied by that agency. (See 28 CFR 16.30 through 16.34.)
- You have the right to expect that officials receiving the results of the criminal history record check will use it only for authorized purposes and will not retain or disseminate it in violation of federal statute, regulation or executive order, or rule, procedure or standard established by the National Crime Prevention and Privacy Compact Council.³

Updated 11/6/2019

I acknowledge receipt of the FBI Privacy Act Statement and Noncriminal Justice Applicant's Privacy Rights.

Nina Bianca Yli-Pippari
Print Name

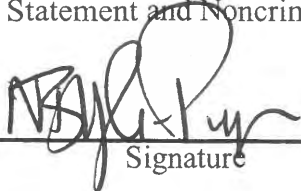
Signature

MAY 14, 2024
Date

¹ Written notification includes electronic notification, but excludes oral notification. ² <https://www.fbi.gov/services/cjis/compact-council/privacy-act-statement>
³ Sec 5 U.S.C. 552a(b); 28 U.S.C. 534(b); 34 U.S.C. § 40316 (formerly cited as 42 U.S.C. § 14616), Article IV(c); 28 CFR 20.21(c), 20.33(d) and 906.2(d).

I/We hereby authorize the Comptroller, his duly authorized deputies, inspectors and clerks, the Board of License Commissioners of Worcester County, its duly authorized agents and employees, any peace officer of Worcester County, to inspect without warrant, the premises upon which said business is to be conducted, and any and all parts of the building in which said business is to be conducted, at any and all hours, and further state that I/We have personally obtained the signatures of the ten citizens to the certificate which is a part hereof.

(Extract from the law: If any affidavit or oath required under the provisions of this Act shall contain any false statements, the offender shall be deemed guilty of perjury, and upon indictment and conviction thereof shall be subject to the penalties provided by the law for that crime.)

Give name(s) and address(es) of officers:

Ameerah Aiyana Harris (name) Managing Member (title) [Redacted] (residence)

Natethan Robert Richard Sample (name) Managing Member (title) [Redacted] (residence)

Nina Bianca Yli-Piipari (name) Member (title) [Redacted] (residence)

If applicant is a Corporation, President or Vice-President must sign:

All Applicants must sign:

- 1. [Signature] (Signature of applicant)
2. [Signature] (Signature of applicant)
3. [Signature] (Signature of applicant)

STATE OF Maryland COUNTY OF Wicomico TO WIT:
THIS CERTIFIES, That on the 14th day of May, 2026, before the subscriber, a Notary Public of the State of Maryland personally appeared Ameerah Aiyana Harris

the applicant(s) named in the foregoing application, and made oath in due form of law that the statements therein are true to the best of his/her knowledge and belief.

WITNESS my hand and notarial seal.

[Signature] NOTARY PUBLIC
My Commission Expires: 1-17-2030

STATE OF Maryland COUNTY OF Wicomico TO WIT:
THIS CERTIFIES, That on the 14th day of May, 2026, before the subscriber, a Notary Public of the State of Maryland personally appeared Natethan Robert Richard Sample

the applicant(s) named in the foregoing application, and made oath in due form of law that the statements therein are true to the best of his/her knowledge and belief.

WITNESS my hand and notarial seal.

[Signature] NOTARY PUBLIC
My Commission Expires: 1-17-2030

STATE OF Maryland COUNTY OF Wicomico TO WIT:
THIS CERTIFIES, That on the 14th day of May, 2026, before the subscriber, a Notary Public of the State of Maryland personally appeared Nina Bianca Yli-Piipari

the applicant(s) named in the foregoing application, and made oath in due form of law that the statements therein are true to the best of his/her knowledge and belief.

WITNESS my hand and notarial seal.

[Signature] NOTARY PUBLIC
My Commission Expires: 1-17-2030

**STATEMENT OF OWNER OF PREMISES REQUIRED IN CONNECTION WITH
ALCOHOLIC BEVERAGES LAW OF MARYLAND**

I/WE HEREBY CERTIFY, That I am/we the owner(s) of record of the property known as 54 Riccio, IL
40 Robert Riccio

named in the foregoing application made to the Board of License Commissioners under the Alcoholic Beverage Laws of Maryland; that I/we assent to the granting of the license applied for; that I/we hereby authorize the State Comptroller, his duly authorized deputies, inspectors and clerks, the Board of License Commissioners for Worcester County, its duly authorized agents and employees, and any peace officer of such county to inspect and search, without warrant, the premises upon which the business is to be conducted, and any and all parts of the building in which said business is to be conducted, at any and all hours.

WITNESS, our/my hand(s) and seal(s) this 7th day of May 2026

[Signature] (seal) _____ (seal)
_____ (seal) _____ (seal)

STATE OF Maryland COUNTY OF Worcester TO WIT:
THIS CERTIFIES, That on the 7 day of May, 2026, before the subscriber, a Notary Public of the State of Maryland personally appeared Robert J. Riccio

and acknowledged the execution of the foregoing statement to be his act.

WITNESS my hand and notarial seal.
(Seal) _____ NOTARY PUBLIC Linda J Kessing
Commission exp 2/19/2

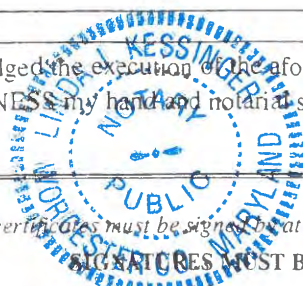

(The following certificates must be signed by at least ten persons.)

SIGNATURES MUST BE OBTAINED BY THE RESIDENT, IF APPLICATION IS FOR CORPORATION.

We the undersigned reputable citizens (real estate owners, registered voters with Worcester County and reside within the tax district in which the business covered by the foregoing application is to be conducted) certify that each of us has been personally acquainted with the applicant for the length of time indicated after our respective names; that we have examined the application of the applicant and that we have good reason to believe that all of the statements contained in said application are true, and that we are familiar with the premises upon which the proposed business is to be conducted and we believe such premises are suitable for the conduct of the business of retail dealer in alcoholic beverages, and that we are of the opinion that the applicant is a suitable person to obtain the license applied for:

(Print name above signature)	Name	Address	Voting Residence	Length of time acquainted with applicant(s). If not acquainted prior to application filing, indicate "Just Met." (All three blanks must be filled in.)
<u>[Signature]</u>	<u>Howard Nichols</u>	<u>10th</u>	<u>304 S Ba Himore Ave Ocean City MD 21842</u>	App. 1 <u>Just met</u> App. 2 <u>Just met</u> App. 3 <u>8 yrs</u>
<u>[Signature]</u>	<u>Haley A. Baiman</u>	<u>20</u>	<u>13700 Barge Rd Ocean City MD 21842</u>	App. 1 <u>Just met</u> App. 2 <u>Just met</u> App. 3 <u>5 yrs</u>
<u>[Signature]</u>	<u>Julia Laurentzani</u>	<u>10th Dist</u>	<u>311 Tuna Lane Ocean City MD 21842</u>	App. 1 <u>Just met</u> App. 2 <u>Just met</u> App. 3 <u>Just met</u>
<u>[Signature]</u>	<u>Michael S. Frisari</u>	<u>10th</u>	<u>613 Twin Tree Rd Ocean City, MD 21842</u>	App. 1 <u>Just met</u> App. 2 <u>Just met</u> App. 3 <u>Just met</u>
<u>[Signature]</u>	<u>Laura J. Phipps</u>	<u>10</u>	<u>613 Twin Tree Rd Ocean City, MD 21842</u>	App. 1 <u>Just met</u> App. 2 <u>Just met</u> App. 3 <u>Just met</u>
<u>[Signature]</u>	<u>Laura J. Phipps</u>	<u>10</u>	<u>403 Fountain Rd</u>	App. 1 <u>Just met</u> App. 2 <u>Just met</u> App. 3 <u>50 yrs</u>
<u>[Signature]</u>	<u>Kathleen A. Ottara O'Hara</u>	<u>#10 (2)</u>	<u>907 139th St. Ocean City MD 21842</u>	App. 1 <u>Just met</u> App. 2 <u>Just met</u> App. 3 <u>10 yrs.</u>
<u>[Signature]</u>	<u>Edward Cameron</u>	<u>10</u>	<u>119 Penny Lane OC MD</u>	App. 1 <u>Just met</u> App. 2 <u>Just met</u> App. 3 <u>2 yrs</u>
<u>[Signature]</u>	<u>Samantha Goodling</u>	<u>10</u>	<u>12917 Rigger Ridge Rd OC MD</u>	App. 1 <u>Just met</u> App. 2 <u>Just met</u> App. 3 <u>Just met</u>
<u>[Signature]</u>	<u>Rocco DiNapoli</u>	<u>10th</u>	<u>12917 Rigger Ridge Rd 21842</u>	App. 1 <u>Just met</u> App. 2 <u>Just met</u> App. 3 <u>Just met</u>
<u>[Signature]</u>	<u>Russell Laurentzani</u>	<u>10th</u>	<u>2985 Inlet Isle Ln OC MD</u>	App. 1 <u>Just met</u> App. 2 <u>Just met</u> App. 3 <u>Just met</u>
<u>[Signature]</u>	<u>[Signature]</u>	<u>10th</u>	<u>311 Tuna Lane OC MD 21842</u>	App. 1 <u>Just met</u> App. 2 <u>Just met</u> App. 3 <u>Just met</u>

Names and addresses of signers must be printed or typewritten above signatures.



Worcester County

BOARD OF LICENSE COMMISSIONERS

1:20 -

Meeting/Taphouse West – (License #911)
Class “B” B/W/L 7 Day License
Request to expand the licensed premises
Request for multiple outside games
12513 Ocean Gateway/Ocean City



**BOARD OF LICENSE COMMISSIONERS
FOR WORCESTER COUNTY
STAFF REPORT
NARRATIVE**

Type: Request to expand Licensed Premise

Date: 5/20/2026

License No: 911

Class: "D"

Type: Beer – Wine – Liquor 7 day

APPLICANT(S): 1. Zev Sibony 2.
3. 4.

TRADE NAME: Taphouse West

CORP: West O.C Taphouse, LLC.

LOCATION: 12513 Ocean Gateway, Ocean City

Restrictions: Live entertainment allowed with a maximum of three pieces amplified inside only five days per week until midnight, one outside speaker allowed until 8 p.m., no disc jockey allowed, garage doors must be closed during all live entertainment, one video game allowed, two pool tables allowed, two pinball machines allowed, one electric dartboard allowed, no off sale

SPECIAL NOTE - Please be aware of an attached additional supplemental report dated May 18, 2026.

The licensee, Zev Sibony, is requesting to expand his licensed premises to include the outside area facing Keyser Point Road and running parallel to the building. In this new area, the licensee would like to add seating, three (3) cornhole games, a Kan Jam (flying disc game) area and potentially one more game. This area would be fully enclosed with a fence along the east side (Keyser Point Road) with controlled access points via gates on the north and south sides. The proposed outside area would be approximately 1,000 sq. ft.

Joseph Pembroke
Liquor License Inspector

April Payne
Liquor License Administrator



BOARD OF LICENSE COMMISSIONERS
FOR WORCESTER COUNTY
NARRATIVE

Type: *Unauthorized use of side yard and games*

Supplemental Report

Date: 5/18/2026

License No: 911

Class: "D"

Type: Beer – Wine – Liquor 7 day

APPLICANT(S): 1. Zev Sibony 2.
 3. 4.

TRADE NAME: *Taphouse West*

CORP: *West O.C Taphouse, LLC.*

LOCATION: 12513 Ocean Gateway, Ocean City

Restrictions: Live entertainment allowed with a maximum of three pieces amplified inside only five days per week until midnight, one outside speaker allowed until 8 p.m., no disc jockey allowed, garage doors must be closed during all live entertainment, one video game allowed, two pool tables allowed, two pinball machines allowed, one electric dartboard allowed, no off sale

On Sunday, May 17, 2026, at approximately 2:45 p.m., Liquor License Administrator, April Payne, received information regarding the property utilizing the exterior side yard. The information reflected the property was allowing patrons to play cornhole and allegedly allowing those patrons to consume beer and possibly other alcoholic beverages.

Administrator Payne called Zev Sibony at 3:21 p.m. to address the photographs which she received showing patrons using the side yard. Administrator Payne advised Mr. Sibony that the property had not been approved to use the side yard as a part of its licensed property nor to use the area for any games. Mr. Sibony told Administrator Payne that he was in Rehoboth and would call the manager at the restaurant immediately.

Administrator Payne additionally sent a text message to Mr. Sibony requesting that he send pictures to her phone showing the area shut down. Mr. Sibony did comply with and provided a photograph confirming the area had been shut down. Mr. Sibony stated through text messages that once a manager noticed drinks outside, he stated it was addressed within a couple of minutes.

For additional information purposes, Administrator Payne and Liquor License Inspector, Joseph Pembroke, were out meeting with applicants on Tuesday May 5th and Administrator Payne noticed some construction equipment on the side of the building and stopped by the property after calling Mr. Sibony and asking him to meet us there. Administrator Payne explained that the activity which was taking place and the intended purpose of the space had not been approved by the Board and will require a hearing. Administrator Payne informed Mr. Sibony of the necessary steps which needed to be taken. As previously discussed with Mr. Sibony, Administrator Payne had already received a written request requesting a meeting before the Board to expand the licensed premises and to allow games in the side yard prior to Sunday, May 17th.

Joseph Pembroke
Liquor License Inspector

April Payne
Liquor License Administrator

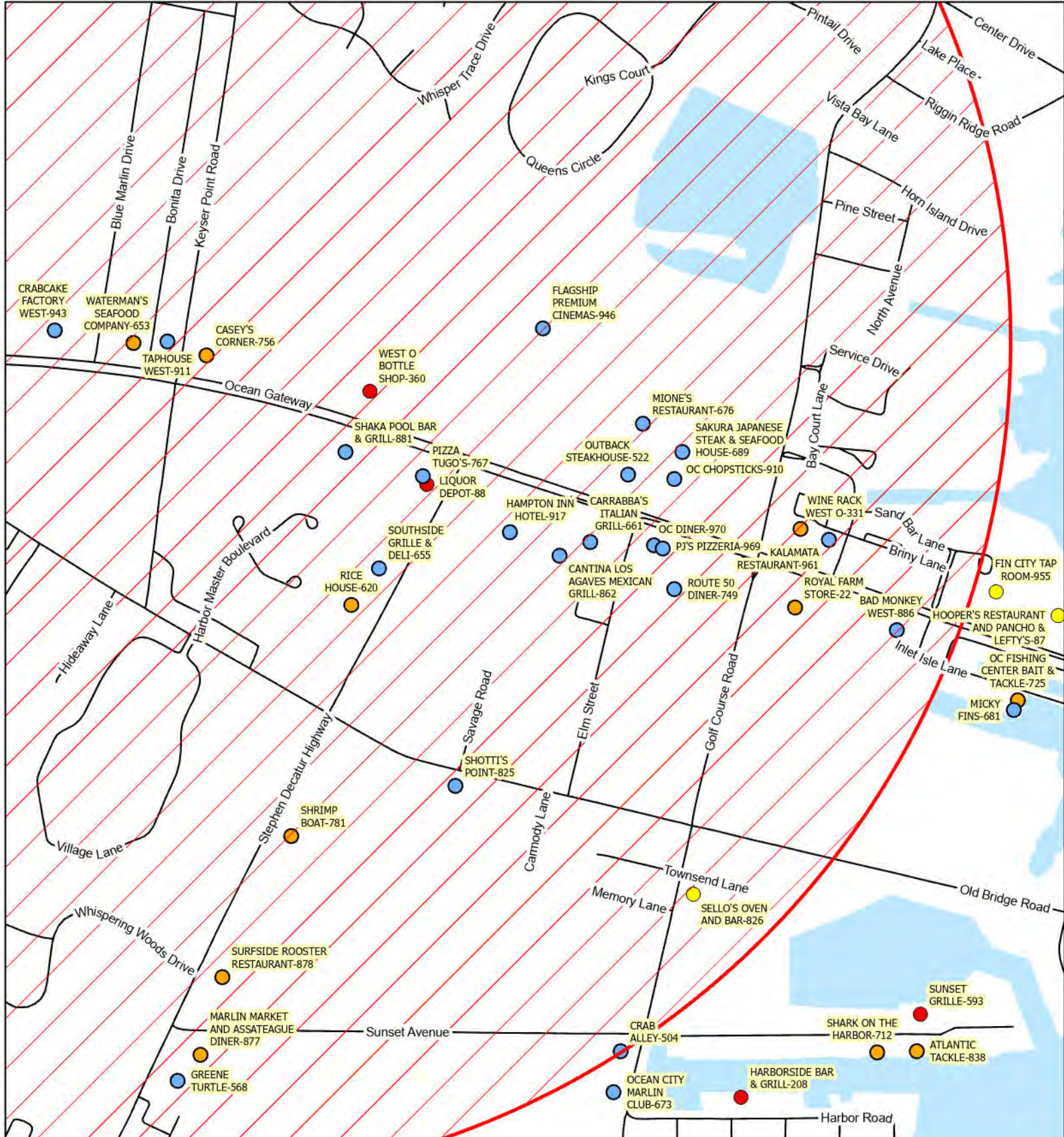

Worcester County Board of License Commissioners

Request to expand licensed premise and to modify entertainment
 Class "B" B/W/L - 7 Day
 Taphouse West - License No. 911



Request to expand licensed premise and to modify entertainment - Taphouse West

License No.	Class	License Type	Off Premise Sale	Trading As...	Distance (Linear Feet)
886	B	BWL	N	BAD MONKEY WEST	4922
862	B	BWL	N	CANTINA LOS AGAVES MEXICAN GRILL	2863
661	B	BWL	N	CARRABBA'S ITALIAN GRILL	2925
756	A	BW	BW	CASEY'S CORNER	185
504	B	BWL	N	CRAB ALLEY	5279
943	B	BWL	N	CRABCAKE FACTORY WEST	707
946	B	BW	N	FLAGSHIP PREMIUM CINEMAS	2347
568	D	BWL	N	GREENE TURTLE	4627
917	B	BW	N	HAMPTON INN HOTEL	2479
961	B	BWL	N	KALAMATA RESTAURANT	4347
88	D	BWL	BWL	LIQUOR DEPOT	1833
877	B	BWL	BW	MARLIN MARKET AND ASSATEAGUE DINER	4450
676	B	BW	N	MIONE'S RESTAURANT	3022
910	B	BW	N	OC CHOPSTICKS	3285
970	B	BWL	N	OC DINER	3318
522	B	BWL	N	OUTBACK STEAKHOUSE	3013
767	B	BWL	N	PIZZA TUGO'S	1819
969	B	BWL	N	PJ'S PIZZERIA	3377
620	B	BWL	BW	RICE HOUSE	2016
749	B	BWL	N	ROUTE 50 DINER	3530
22	A	BW	BW	ROYAL FARM STORE	4272
689	B	BWL	N	SAKURA JAPANESE STEAK & SEAFOOD HOUSE	3301
826	B	BWL	W	SELLO'S OVEN AND BAR	4771
881	B	BWL	N	SHAKA POOL BAR & GRILL	1270
825	B	BWL	N	SHOTTI'S POINT	3309
781	B	BW	BW	SHRIMP BOAT	3551
655	B	BW	N	SOUTHSIDE GRILLE & DELI	1939
878	B	BWL	BW	SURFSIDE ROOSTER RESTAURANT	3991
911	B	BWL	N	TAPHOUSE WEST	0
653	B	BWL	BW	WATERMAN'S SEAFOOD RESTAURANT	199
360	D	BWL	BWL	WEST O BOTTLE SHOP	1302
331	A	BW	BW	WINE RACK WEST O	4142





3:28 📴

< West OC Tap-





 Live View



8X



< Today



11:00

12:00

13:00



13:09:06



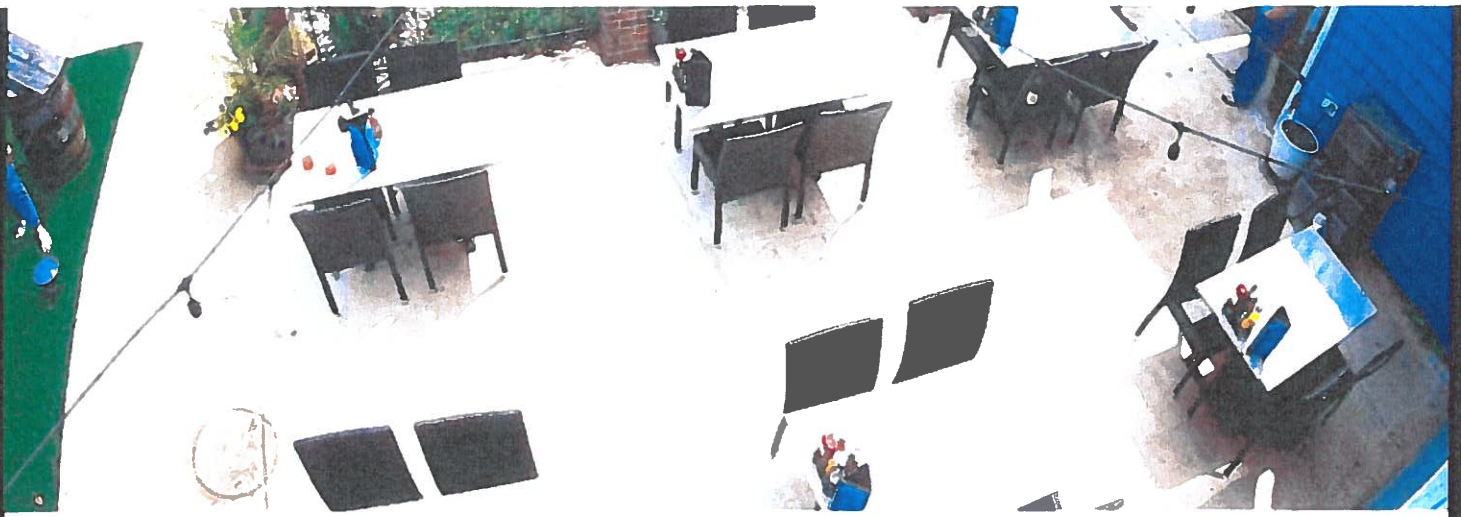

 Live View



1X



< Today >



11:00

12:00

13:00

14:00

15:00



13:18:00





STOWAN'S
SPORT

L/G





Z Group Hospitality, Ltd

DBA: West OC Taphouse



4507 Coastal Highway
Ocean City, MD 21842

P: (443) 664-2201

F: (443) 664-2202

E:

oceancitytaphouse@gmail.com

Z Group Hospitality, Ltd
4507 Coastal Highway
Ocean city, MD 21842

Dear April,

I hope you're doing well. I am writing to formally request an expansion of the licensed premises for Taphouse West Ocean City. Currently, our license includes the existing front outdoor patio seating area. I would like to extend the premises by approximately 1,000 square feet along the side of the building. This additional space would allow us to add more seating, along with a few recreational activities for our guests, such as three cornhole setups, a Can Jam area, and potentially one additional game. The expanded area would be fully enclosed with a fence along the east side (Keyser Point Road), with controlled access points via gates on the north and south sides. Please let me know if you need any additional information or documentation to support this request. I appreciate your time and consideration.

Zev Sibony
Ocean City Taphouses
443-664-2201

Joseph B. Pembroke

From: April Payne
Sent: Monday, May 18, 2026 8:18 AM
To: Joseph B. Pembroke
Subject: RE: Incident on 05/17 - Taphouse West

Print this one instead.

April R. Payne
Liquor License Administrator
Worcester County Board of License Commissioners
One West Market Street – Room 1201
Snow Hill, Maryland 21863
Phone: 410-632-1908, Ext. #1120
Fax: 410-632-3008
Email: apayne@worcestermd.gov
County Website: [Board of License Commissioners Webpage](#)



This e-mail may contain confidential and privileged material for the sole use of the intended recipient. Any review, use, distribution or disclosure by others is strictly prohibited. If you are not the intended recipient (or authorized to receive for the recipient), please contact the sender by reply e-mail and delete all copies of this message.

From: April Payne
Sent: Monday, May 18, 2026 8:17 AM
To: 'Zev Sibony' <zev.sibony@gmail.com>
Subject: RE: Incident on 05/17 - Taphouse West

Good morning:

Thank you for the additional information relative to the incident yesterday.

April R. Payne
Liquor License Administrator
Worcester County Board of License Commissioners
One West Market Street – Room 1201
Snow Hill, Maryland 21863
Phone: 410-632-1908, Ext. #1120
Fax: 410-632-3008
Email: apayne@worcestermd.gov
County Website: [Board of License Commissioners Webpage](#)



This e-mail may contain confidential and privileged material for the sole use of the intended recipient. Any review, use, distribution or disclosure by others is strictly prohibited. If you are not the intended recipient (or authorized to receive for the recipient), please contact the sender by reply e-mail and delete all copies of this message.

From: Zev Sibony <zev.sibony@gmail.com>
Sent: Sunday, May 17, 2026 3:34 PM
To: April Payne <apayne@worcestermd.gov>
Subject: Incident on 05/17

Good afternoon April

Unfortunately this is not a great incident and now not great afternoon. Since our call, I called my general manager who is off today. The manager on duty is my bar manager Zachary. He explicitly told the guests to leave their drinks inside or on the front patio where alcohol is allowed. Please see attached image of drinks on said tables.

Now the issue of cornhole is another conversation. Yes We have the sets and customers must have been playing. Zac has been informed of this. Unfortunately he's filling in for my general manager today who is out of town. I don't have any cameras on that Side of the building yet. From Gathering info from my staff, they were outside. A server saw and informed Zac and he went to address it with the guests.

This is all the information I can gather in such short notice. I hope this helps. If there's anything else o can do, please let me know. Thank you.

Zev Sibony
Owner / Operator
Z Group Hospitality LTD
4507 Coastal Highway
Ocean City Maryland 21842
P- 443-664-2201
C- 732-284-0046



Worcester County

BOARD OF LICENSE COMMISSIONERS

- 1:30 - Meeting/Caruso Pizza & Wild Bill's – (License #816)
Class "B" B/W/L 7 Day License
Request to expand the licensed premises for Bike Week on
September 9, 2026 - September 12, 2026 during the hours of 12 p.m.
until 12 a.m. in adjacent parking lot
Request for live entertainment for Bike Week on September 9, 2026
- September 12, 2026 during the hours of 12 p.m. until 12 a.m. in
adjacent parking lot
Request to redefine the licensed property
420 Atlantic Avenue & Boardwalk/Ocean City



**BOARD OF LICENSE COMMISSIONERS
FOR WORCESTER COUNTY
STAFF REPORT
NARRATIVE**

Type: Request for Bike Week
And redefine the licensed premise

Date 5/19/2026

License No: 816

Class: "B"

Type: Beer – Wine – Liquor 7 Day

APPLICANT(S): 1. William H. Purnell III 2.
3. 4.

TRADE NAME: Caruso Pizza and Wild Bill's

CORP: OC Taco Truck, Inc.

LOCATION: 420 Atlantic Avenue and Boardwalk, Ocean City

Restrictions: Caruso Pizza - no live entertainment Wild Bill's - no outside entertainment, license premises includes property at 403 s. Baltimore avenue known as Wild Bill's on full time basis with the following restrictions: live entertainment allowed seven days per week with a maximum of six pieces from 11:00 a.m. until 2:00 a.m., no disc jockey allowed, Wild Bill's - pool bar service allowed, food must be served between 12 p.m. until 9 p.m. daily, Wild Bill's - two pool tables allowed, five tabletop games allowed, Caruso Pizza & Wild Bill's - no off sale

SPECIAL NOTE - Please be aware of two attached additional supplemental reports dated April 23, 2026 and May 17, 2026.

The licensee would like to expand his licenses premises to include the parking lot of the Atlantic Hotel for Bike week. The dates would be Wednesday September 9th to Saturday September 12th. The licensee would like the hours to be 12 p.m. until 12 a.m. during those days of the event.

The licensee would like to have a stage for live entertainment that would be behind Caruso's in the parking lot consisting of five (5) or six (6) pieces, two (2) bar areas measuring 10 x 20, located behind Wild Bill's and behind Caruso's (all within the parking lot). The licensee will also have a BBQ station and a table selling t-shirts.

Furthermore, Mr. Purnell would like to redefine and decrease his license property to not include his private residence, driveway and storage building.

Joseph Pembroke
Liquor License Inspector

April Payne
Liquor License Administrator



**BOARD OF LICENSE COMMISSIONERS
FOR WORCESTER COUNTY
NARRATIVE**

Type: Follow Up

Supplemental Report

DATE: 4/23/2026

License No: 816

Class: "B"

Type: Beer – Wine - Liquor

APPLICANT(S): 1. William H. Purnell 2.
3. 4.

TRADE NAME: Caruso Pizza and Wild Bill's

CORP: OC Taco Truck, Inc.

LOCATION: 420 Atlantic Avenue and Boardwalk Ocean City

Restrictions: CARUSO PIZZA - NO LIVE ENTERTAINMENT WILD BILL'S - NO OUTSIDE ENTERTAINMENT, LICENSE PREMISES INCLUDES PROPERTY AT 403 S. BALTIMORE AVENUE KNOWN AS WILD BILL'S ON FULL TIME BASIS WITH THE FOLLOWING RESTRICTIONS: LIVE ENTERTAINMENT ALLOWED SEVEN DAYS PER WEEK WITH A MAXIMUM OF SIX PIECES FROM 11:00 A.M. UNTIL 2:00 A.M., NO DISC JOCKEY ALLOWED, WILD BILL'S - POOL BAR SERVICE ALLOWED, FOOD MUST BE SERVED BETWEEN 12 P.M. UNTIL 9 P.M. DAILY, WILD BILL'S - TWO POOL TABLES ALLOWED, FIVE TABLETOP GAMES ALLOWED, CARUSO PIZZA & WILD BILL'S - NO OFF SALE

On Thursday April 23rd, 2026 at 9:05 A.M., Liquor License Administrator, April Payne, and Liquor License Inspector, Joseph Pembroke, met with licensee holder William Purnell to conduct a follow up to review the license premises and its boundaries which had been accepted and approved at the April 15th Board meeting. After the April 15th Board meeting, Mr. Purnell applied for a Special Permit for Bike Week and gave Administrator Payne a site plan that was different than what was approved at the April 15th Board meeting. Mr. Purnell said that his private residence, Hemp shop and private alley way should not have been included in what was submitted to the Board. Liquor License Administrator, April Payne, and Liquor License Inspector, Joseph Pembroke, visited the property to thoroughly understand what had been approved and what Mr. Purnell would like changed. Photographs were taken to clearly identify all aspects of the property. Mr. Purnell indicated that he would like to change the licensed premise description to represent what he submitted to Administrator Payne for the Special Permit request. Administrator Payne informed Mr. Purnell that she would schedule a meeting with the Board for their June meeting to discuss the Bike Week request as well as the request to modify the licensed premises.

Joseph Pembroke
Liquor License Inspector

April Payne
Liquor License Administrator



Worcester County Board of License Commissioners
 Request to expand licensed premise, Request to modify
 entertainment and Request to redefine licensed premise
Class "B" B/W/L - 7 Day
Caruso Pizza & Wild Bill's - License No. 816
 Information & Technology - GIS Division - June 2026



Multiple Requests - Caruso Pizza & Wild Bill's

License No.	Class	License Type	Off Premise Sale	Business Name	Linear Distance (Feet)
816	B	BWL	N	CARUSO PIZZA & WILD BILL'S	0
31	D	BWL	BW	CORK BAR	185
10	D	BWL	BWL	BEARDED CLAM	292
761	D	BWL	N	CRAWL STREET TAVERN	341
40	B	BW	N	PIEZANO'S PIZZA	463
91	B	BWL	N	DOUGH ROLLER	569
178	A	BW	BW	O.C. FOOD MARKET	643
535	B	BWL	BW	FAT DADDY'S	752
192	D	BWL	N	PURPLE MOOSE SALOON	971
32	D	BWL	BW	HARBOR INN	1229
16	A	BW	BW	WEAVER'S BEER & WINE	1353
72	B	BWL	BW	INLET LODGE	1371
938	B	BWL	BW	TOAST	1447
286	B	BWL	N	HARRISON'S HARBOR WATCH	1505
113	B	BWL	N	FLAMINGO COAST - VAULT AND LAGUNA ROOFTOP LOUNGE	1568
90	B	BWL	N	OYSTER & SCALES	1608
762	B	BWL	N	GUIDO'S BURRITOS	1734
458	D	BWL	BWL	M.R. DUCKS	1741
171	B	BWL	BWL	ANGLER RESTAURANT	1848
102	B	BWL	N	CABANAS BEACH BAR & GRILLE	2162
242	B	BWL	N	MUG & MALLET	2307
904	B	BWL	N	SPAIN WINE BAR	2358
954	B	BWL	N	VIEW	2358
951	D	BWL	N	PARK PLACE HOTEL	2673
751	B	BWL	BW	LAZY LIZARD BAR & GRILL	2681
668	A	BW	BW	OC DOLLAR STORE	2704
97	B	BWL	N	BULL ON THE BEACH	2757
831	D	BW	N	MONTE CARLO SURF INN	2806
52	B	BWL	N	DOUGH ROLLER	2815
139	B	BWL	N	SHENANIGAN'S IRISH PUB & SEAFOOD HOUSE	3266
958	B	BWL	N	HOOK UP	3497
41	A	BW	BW	MITCHELL'S MARKET	3546
941	B	BW	N	PLANET WINGS RESTAURANT	3710

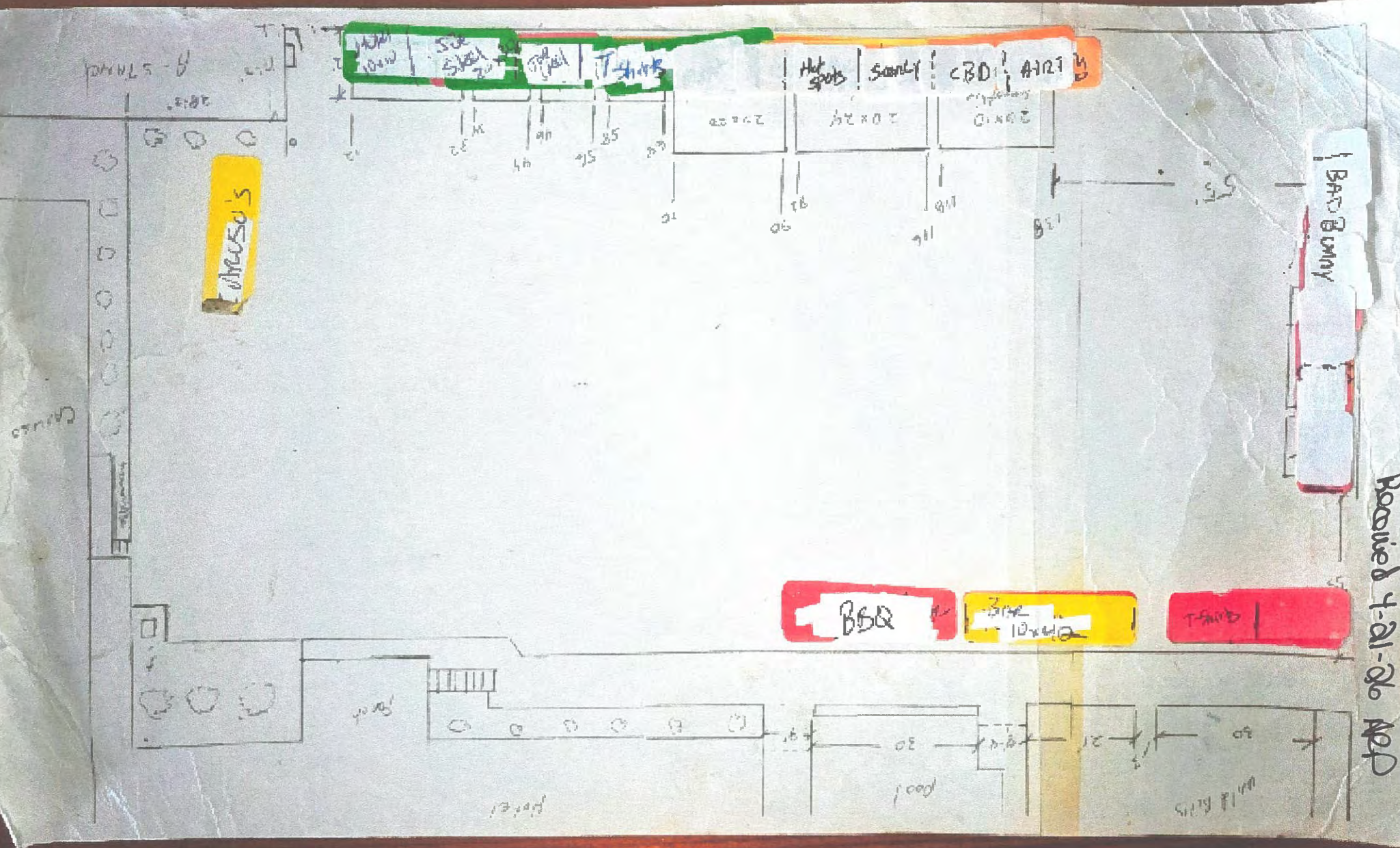

SOS

Hot Spots | Scouty | CBD | ART

Bart Bunny

BBQ

10x10

TABLE

Received 4-21-20 APD



Received
421-216
ARP

Search by address or common

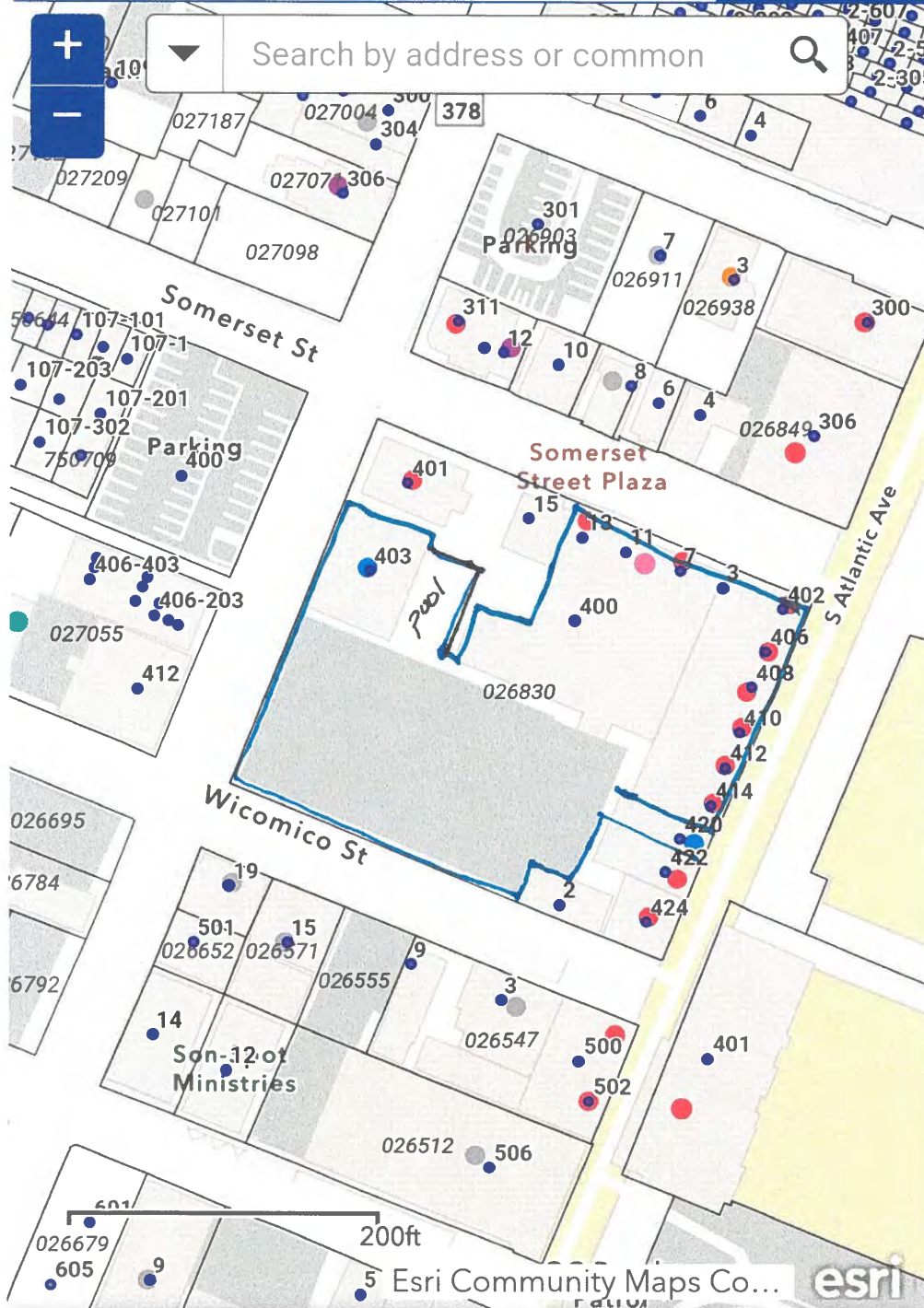

License E-460

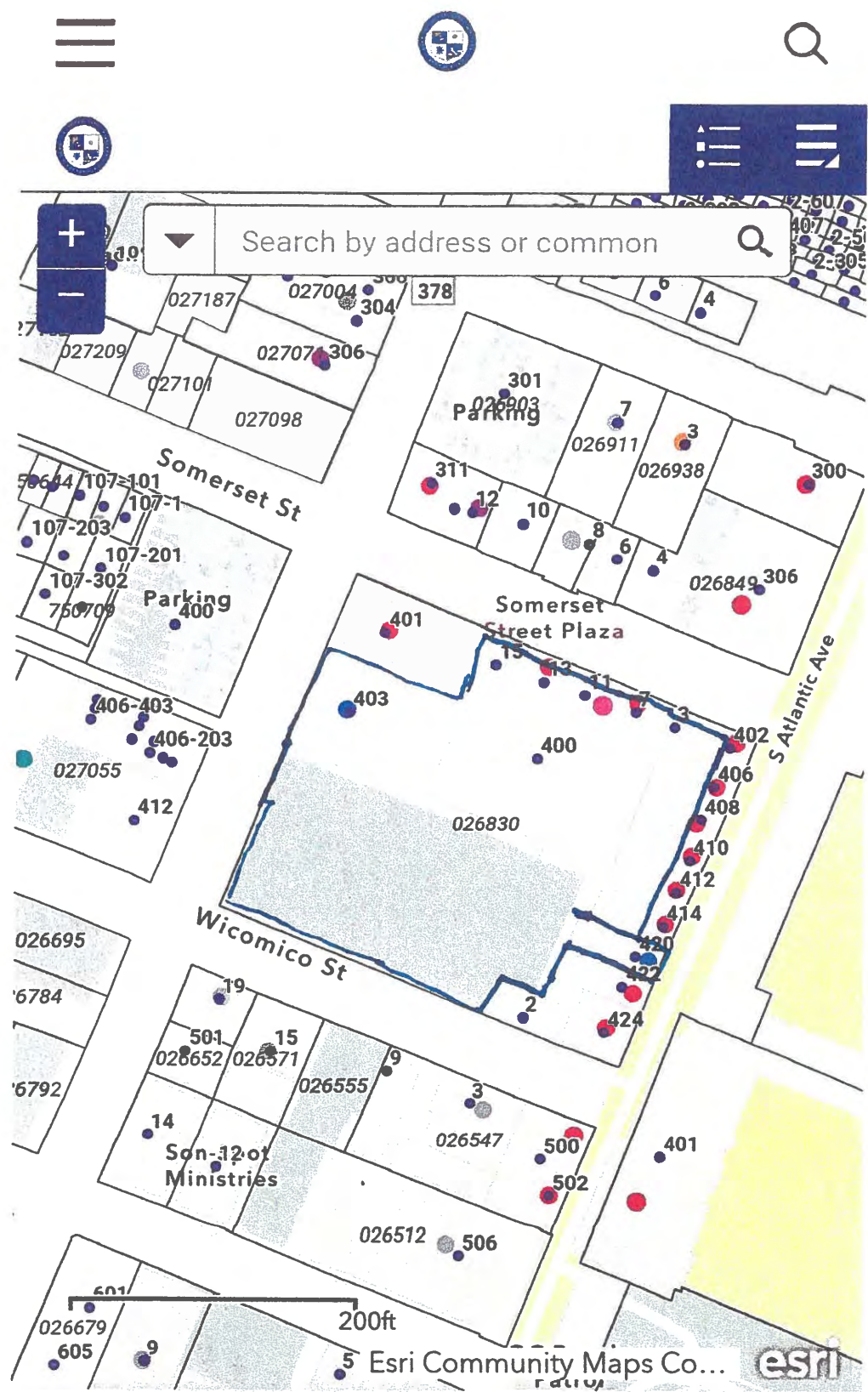

Submitted
@ mtg.
on
4-15-26

403 Wild
Bill's





Inside of Service Window to Pool



Pool entrance looking towards main parking
Outside service window from pool area



Looking from service counter to outside pool gate entrance towards parking lot.



Entrance to private entrance from parking lot



Inside private residence gate



Inside private residence, no public access



Inside private residence, no public access. Used only by employees



Inside private residence, no public access. Gate leading out to Somerset Street



Private residence garage and gate leading to alley, no public access from Somerset Street



Proposed area for future events



Proposed area for future events



Proposed premises to be licensed



Proposed premises to be licensed



Proposed premises to be licensed



Proposed premises to be licensed



Proposed premises to be licensed



Parking lot from looking towards S Baltimore Ave



Parking lot looking towards Caruso's Pizza



Main entrance to Atlantic Hotel from parking lot.



Hemp Shop

401

OPEN
HEMP
SHOP

401 S. Baltimore

Hemp shop



15
Jomraek
St

DO NOT
ENTER

No Left Turn



401 S Baltimore

Somerset St

S Baltimore Ave

Wild Bill's

Atlantic Hotel
4.4 (371)
3-star hotel

Haagen-Dazs

Caruso Pizza
Pizza

Ripley's Believe It or Not!

Pop's Boardwalk

Big Jim's Bikes

Somerset Plaza

The Wrapper
Fast Food

Crawl Street Tavern
Grill

Gracie Ocean City
Jiu Jitsu, Judo

Ultra MX Bitcoin ATM

458498

25

2

Received 4-21-26
ARP

OC TACO TRUCK INC
T/A Caruso Pizza/Wild Bill's
424 S Atlantic Avenue
Ocean City, MD 21842

March 23, 2026

RE: Request for Temporary Extension of Liquor License for Caruso Pizza/Wild Bill's (license #816)

Dear Members of the Board,

I am writing to formally request a temporary extension of liquor license #816 to expand our service area. In addition, I request permission to have live entertainment in this area.

Details are as follows:

Event: Bike Week 2026

Dates: September 9, 2026 through September 12, 2026

Hours: 12 pm to 12am

Location: Parking Lot of Atlantic Hotel in Ocean City

All sales and live entertainment will take place in temporary extension areas during the above hours.

Please let me know if any further information is needed. I look forward to your approval.

Sincerely,



William H Purnell III

410-430-7549

octacotruck@gmail.com



Worcester County

BOARD OF LICENSE COMMISSIONERS

- 1:45 - Meeting/Flamingo Coast – Vault & Laguna Rooftop Lounge
(License #113)
Class “B” B/W/L 7 Day License
Request to change live entertainment hours from 3 p.m. until 11 p.m. to 12
noon until 11 p.m.
3 N. Division Street & Boardwalk/Ocean City



**BOARD OF LICENSE COMMISSIONERS
FOR WORCESTER COUNTY
STAFF REPORT
NARRATIVE**

Type: Request to modify live entertainment

Date: 5/20/2026

License No: 113

Class: "B"

Type: Beer – Wine – Liquor 7 Day

APPLICANT(S): 1. James R. Bergey III 2.
3. 4.

TRADE NAME: Flamingo Coast – Vault and Laguna Rooftop Lounge

CORP:OC Flamingo, LLC

LOCATION: 3 North Division Steet and Boardwalk, Ocean City

Restrictions: Live entertainment with amplification allowed with maximum of five pieces from **3:00 p.m. until 11:00 p.m. on the Rooftop**, or in the main area of the downstairs restaurant or inside the Vault but not at the same time, no off sale.

The licensee is requesting to modify the licensed premises live entertainment hours on the Rooftop Lounge. The licensee would like to increase the live entertainment hours **from 12 p.m.** until 11 p.m. seven (7) days a week. The current restrictions are live entertainment with amplification allowed with a maximum of five pieces **from 3 p.m.** until 11 p.m. on the Rooftop, or in the main area of the downstairs restaurant or inside Vault but not at the same time.

Joseph Pembroke
Liquor License Inspector

April Payne
Liquor License Administrator



Worcester County Board of License Commissioners

Request to modify LIVE entertainment
 Class "B" B/W/L - 7 Day

Flamingo Coast - Vault & Laguna Rooftop Lounge- License No. 113

Information & Technology - GIS Division - June 2026



Request to modify LIVE entertainment - Flamingo Coast

License No.	Class	License Type	Off Premise Sale	Trading As...	Distance (Linear Feet)
113	B	BWL	N	FLAMINGO COAST - VAULT AND LAGUNA ROOFTOP LOUNGE	0
762	B	BWL	N	GUIDO'S BURRITOS	132
16	A	BW	BW	WEAVER'S BEER & WINE	400
102	B	BWL	N	CABANAS BEACH BAR & GRILLE	465
192	D	BWL	N	PURPLE MOOSE SALOON	468
242	B	BWL	N	MUG & MALLET	578
535	B	BWL	BW	FAT DADDY'S	813
40	B	BW	N	PIEZANO'S PIZZA	864
97	B	BWL	N	BULL ON THE BEACH	865
951	D	BWL	N	PARK PLACE HOTEL	930
178	A	BW	BW	O.C. FOOD MARKET	931
52	B	BWL	N	DOUGH ROLLER	976
831	D	BW	N	MONTE CARLO SURF INN	981
668	A	BW	BW	OC DOLLAR STORE	1060
751	B	BWL	BW	LAZY LIZARD BAR & GRILL	1282
139	B	BWL	N	SHENANIGAN'S IRISH PUB & SEAFOOD HOUSE	1329
904	B	BWL	N	SPAIN WINE BAR	1332
954	B	BWL	N	VIEW	1332
816	B	BWL	N	CARUSO PIZZA & WILD BILL'S	1337
171	B	BWL	BWL	ANGLER RESTAURANT	1338
32	D	BWL	BW	HARBOR INN	1343
31	D	BWL	BW	CORK BAR	1366
10	D	BWL	BWL	BEARDED CLAM	1376
761	D	BWL	N	CRAWL STREET TAVERN	1380
458	D	BWL	BWL	M.R. DUCKS	1388
90	B	BWL	N	OYSTER & SCALES	1391
958	B	BWL	N	HOOK UP	1513
41	A	BW	BW	MITCHELL'S MARKET	1619
91	B	BWL	N	DOUGH ROLLER	1672
941	B	BW	N	PLANET WINGS RESTAURANT	1676
938	B	BWL	BW	TOAST	1776
747	B	BWL	N	HOOTER'S OF THE BOARDWALK	1789
594	B	BW	N	FLAVORS OF ITALY	2035
72	B	BWL	BW	INLET LODGE	2300
286	B	BWL	N	HARRISON'S HARBOR WATCH	2405
759	B	BWL	N	PIEZANO'S PIZZA	2508
392	D	BWL	BWL	PICKLES PUB	2666
959	B	BWL	N	TIPSY TACO AT LANKFORD HOTEL	2932
957	B	BWL	N	BIRD DOG TAVERN	3090
437	A	BW	BW	9TH STREET MARKET	3182
672	B	BWL	BWL	HAMMERHEADS RAW BAR & GRILL	3417
440	A	BW	BW	8TH STREET BEER AND WINE	3554



Front of premises



Entrance to the Rooftop lounge from the first floor - Stairway



Looking to the left side of the premises/ bar area



Entertainment area – (Where brown barrel is)



Looking East towards the boardwalk/beach from the entertainment area



Looking towards the beach/boardwalk area from the rooftop deck



Looking towards the boardwalk south from the rooftop deck/bar area



Looking east towards outside bar



Looking towards the exit to the Rooftop deck- Lounge from the bar



Looking west towards the entertainment area



Looking from the rooftop/deck lounge to entertainment and bar area – east to west

Law Offices
AYRES, JENKINS, GORDY & ALMAND, P.A.
6200 COASTAL HIGHWAY, SUITE 200
OCEAN CITY, MARYLAND 21842
www.ajgalaw.com

GUY R. AYRES, III (1945-2019)
JAMES W. ALMAND
WILLIAM E. ESHAM, III
MARK SPENCER CROPPER
BRUCE F. BRIGHT
HEATHER E. STANSBURY
MAUREEN F. L. HOWARTH
RYAN D. BODLEY
BRADFORD F. KIRBY
VICTORIA O'NEILL
SPENCER AYRES CROPPER

EMAIL ADDRESS:
mcropper@ajgalaw.com

(410) 723-1400
FAX (410) 723-1861

May 19, 2026

OF COUNSEL
HAROLD B. GORDY, JR.
M. DEAN JENKINS
ALVIN I. FREDERICK

Ms. April Payne, Administrator
Worcester County Board of License Commissioners
One West Market Street- Room 1201
Snow Hill, MD 21863

Re: OC Flamingo, LLC
Flamingo Coast/Vault and Laguna Rooftop Lounge
Licensed Premises #113 Entertainment Modification Request

Dear April:

On behalf of my client, OC Flamingo, LLC, a Maryland limited liability company ("OC Flamingo"), please accept this request to modify the entertainment approved for the Flamingo Coast-Vault and Laguna Rooftop Lounge licensed premises to increase the permitted live entertainment on the rooftop from 3:00 pm – 11:00 pm to noon - 11:00 pm seven days per week.

OC Flamingo is currently permitted the following entertainment:

- Up to a five-piece band;
- Live entertainment hours on the rooftop from 3:00 pm - 11:00 pm;
- Amplified entertainment;
- Entertainment on the rooftop or inside the Vault;
- Relocation of the band from the rooftop to the main area of the downstairs restaurant during inclement weather;

In support of this request, enclosed is check in the amount of \$200 for the modification request fee.

Should you have any questions about this letter, do not hesitate to give me a call. As always, your cooperation is appreciated.

Very truly yours,

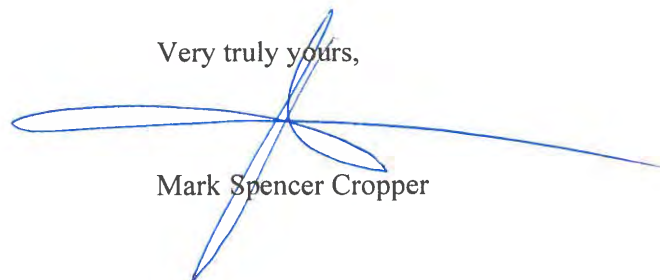

Mark Spencer Cropper

Enclosures



Worcester County

BOARD OF LICENSE COMMISSIONERS

1:55 -

Meeting/Bearded Clam – (License #10)

Class “D” B/W/L 7 Day License

Request to expand the licensed premises

Request to add an outside bar to licensed premises

Request for one cornhole game, and one board game be allowed in the outside bar area

15 Wicomico Street/Ocean City



BOARD OF LICENSE COMMISSIONERS
FOR WORCESTER COUNTY
NARRATIVE

Type: Follow Up regarding Facebook Post
Relative to a new outside bar

Supplemental Report

DATE: 4/23/2026

License No: 10

Class: "D"

Type: Beer - Wine - Liquor

APPLICANT(S): 1. Michael J. Strawley, Jr. 2. Karyn L. Strawley Saunders
3. 4.

TRADE NAME: Bearded Clam

CORP: Mi-Lin, Inc.

LOCATION: 15 Wicomico Street, Ocean City

Restrictions: None

As a result of a Facebook post showing a new outside bar, on Thursday, April 23, 2026, at 10:58 A.M., Liquor License Administrator, April Payne, and Liquor License Inspector, Joseph Pembroke, met with licensee Michael Strawley regarding an outside bar (rear of property) that was built without approval from the Board of License Commissioners. Administrator Payne asked Mr. Strawley about the outside bar and why he didn't get the Board's approval before he built it. Mr. Strawley said he thought we knew about it because he did write it on his 2026 - 2027 renewal application. Please refer to the request for a building permit with the Town of Ocean City on February 25, 2026 ascertained by Inspector Pembroke for our record purposes. Mr. Strawley told Administrator Payne that he thought the Board had come to his premises and approved it. Administrator Payne told Mr. Strawley that she did not visit the location, nor did she send anyone from the Board as she was unaware of the new outside bar. Administrator Payne told Mr. Strawley he should have followed up with her for her guidance as the Board must review and approve any changes to a licensed property.

Administrator Payne told Mr. Strawley the outside bar had to remain closed until he went in front of the Board of License Commissioners at their meeting in June. Administrator Payne explained to Mr. Strawley what he needed to send to her to get on to the agenda for their June meeting. Mr. Strawley said he would follow up with what Administrator Payne informed him to do and send in the request.

Joseph Pembroke
Liquor License Inspector

April Payne
Liquor License Administrator



Worcester County Board of License Commissioners
 Request to expand and modify licensed
 premise and Request to modify entertainment
 Class "D" B/W/L - 7 Day
 Bearded Clam - License No. 10
 Information & Technology - GIS Division - June 2026



Request to expand and modify licensed premise and to modify entertainment - Bearded Clam

License No.	Class	License Type	Off Premise Sale	Trading As...	Distance (Linear Feet)
10	D	BWL	BWL	BEARDED CLAM	0
761	D	BWL	N	CRAWL STREET TAVERN	60
31	D	BWL	BW	CORK BAR	180
816	B	BWL	N	CARUSO PIZZA & WILD BILL'S	292
91	B	BWL	N	DOUGH ROLLER	451
178	A	BW	BW	O.C. FOOD MARKET	672
759	B	BWL	N	PIEZANO'S PIZZA	678
535	B	BWL	BW	FAT DADDY'S	816
32	D	BWL	BW	HARBOR INN	1073
192	D	BWL	N	PURPLE MOOSE SALOON	1161
938	B	BWL	BW	TOAST	1199
72	B	BWL	BW	INLET LODGE	1204
286	B	BWL	N	HARRISON'S HARBOR WATCH	1348
16	A	BW	BW	WEAVER'S BEER & WINE	1470
90	B	BWL	N	OYSTER & SCALES	1476
458	D	BWL	BWL	M.R. DUCKS	1635
171	B	BWL	BWL	ANGLER RESTAURANT	1755
113	B	BWL	N	FLAMINGO COAST - VAULT AND LAGUNA ROOFTOP LOUNGE	1757
762	B	BWL	N	GUIDO'S BURRITOS	1926
904	B	BWL	N	SPAIN WINE BAR	2325
954	B	BWL	N	VIEW	2325
102	B	BWL	N	CABANAS BEACH BAR & GRILLE	2346
242	B	BWL	N	MUG & MALLETT	2490
751	B	BWL	BW	LAZY LIZARD BAR & GRILL	2632
668	A	BW	BW	OC DOLLAR STORE	2797
951	D	BWL	N	PARK PLACE HOTEL	2852
97	B	BWL	N	BULL ON THE BEACH	2939
831	D	BW	N	MONTE CARLO SURF INN	2967
52	B	BWL	N	DOUGH ROLLER	2998
139	B	BWL	N	SHENANIGAN'S IRISH PUB & SEAFOOD HOUSE	3443
958	B	BWL	N	HOOK UP	3663
41	A	BW	BW	MITCHELL'S MARKET	3664
941	B	BW	N	PLANET WINGS RESTAURANT	3889



Front entrance to the Bearded Clam

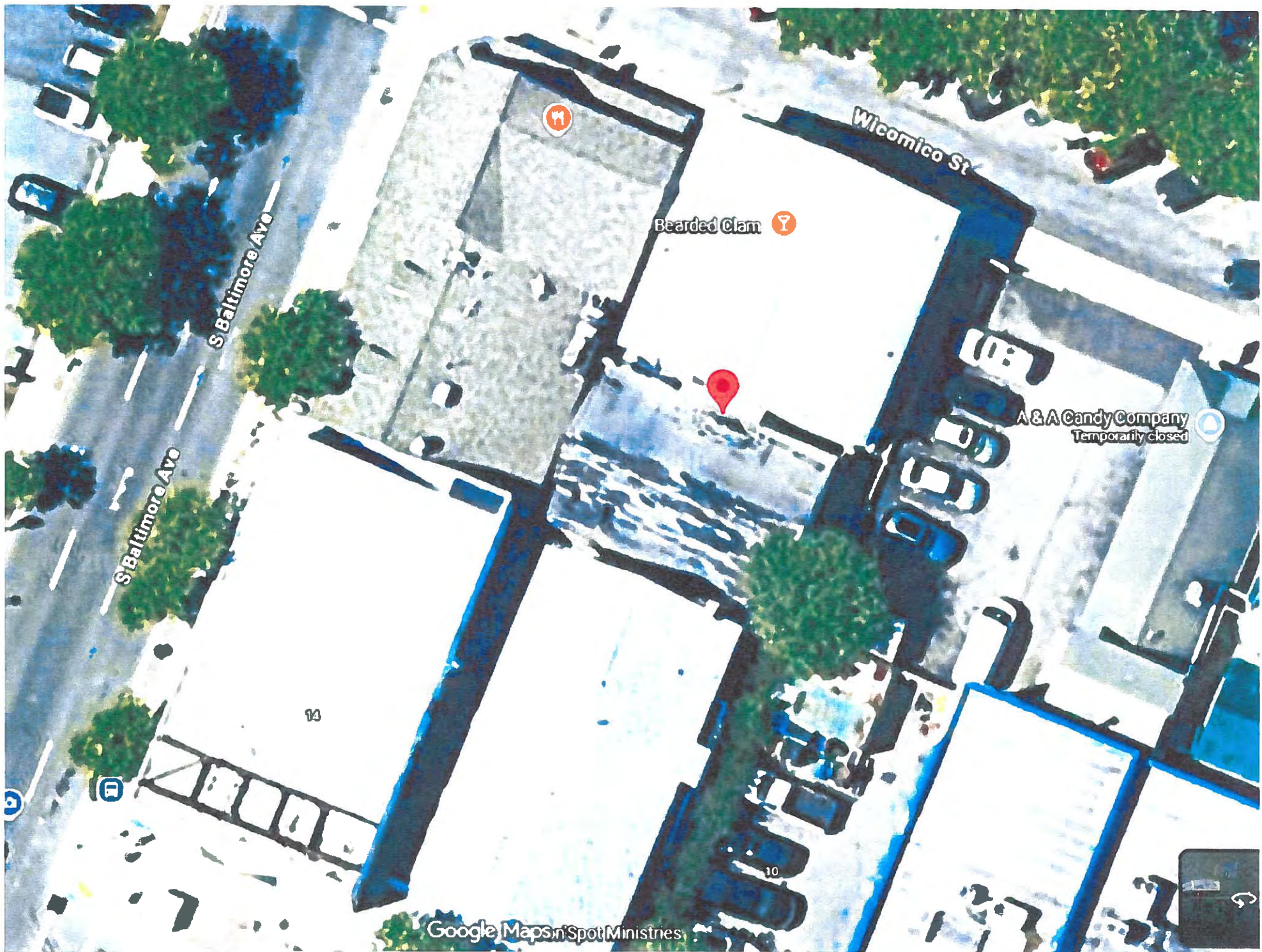





Entrance to back-bar area from rear of licensed premises



Entrance to main bar from Back bar area



Right Side of back outside bar area



Left Side of back outside bar area



Back bar



Back Bar Open



Back Bar Open



Back Bar Area



Right Side of Bar area looking from the left side



Inside of outside Bar

The Bearded Clam Lounge #10

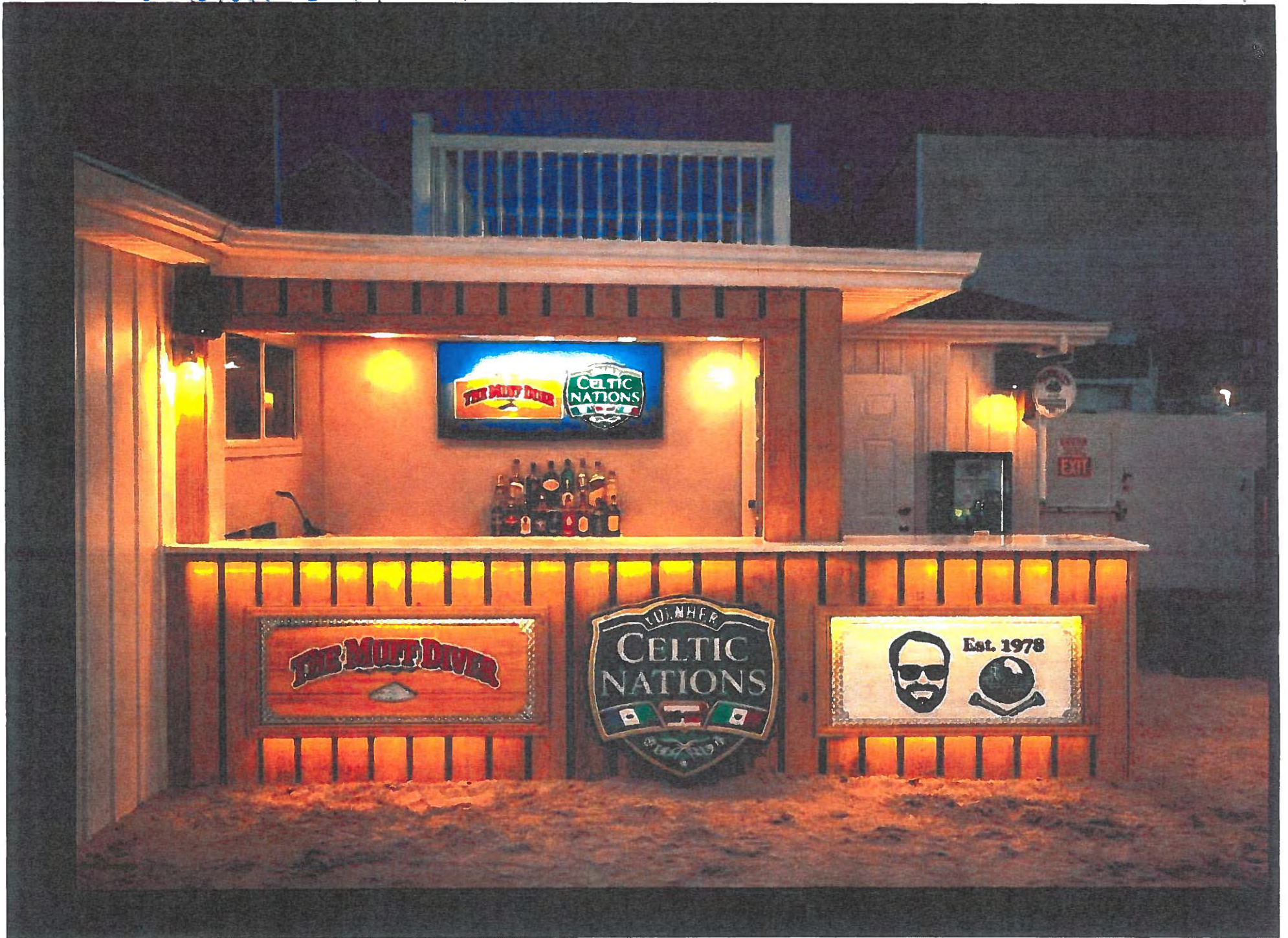

Bearded Clam License #10

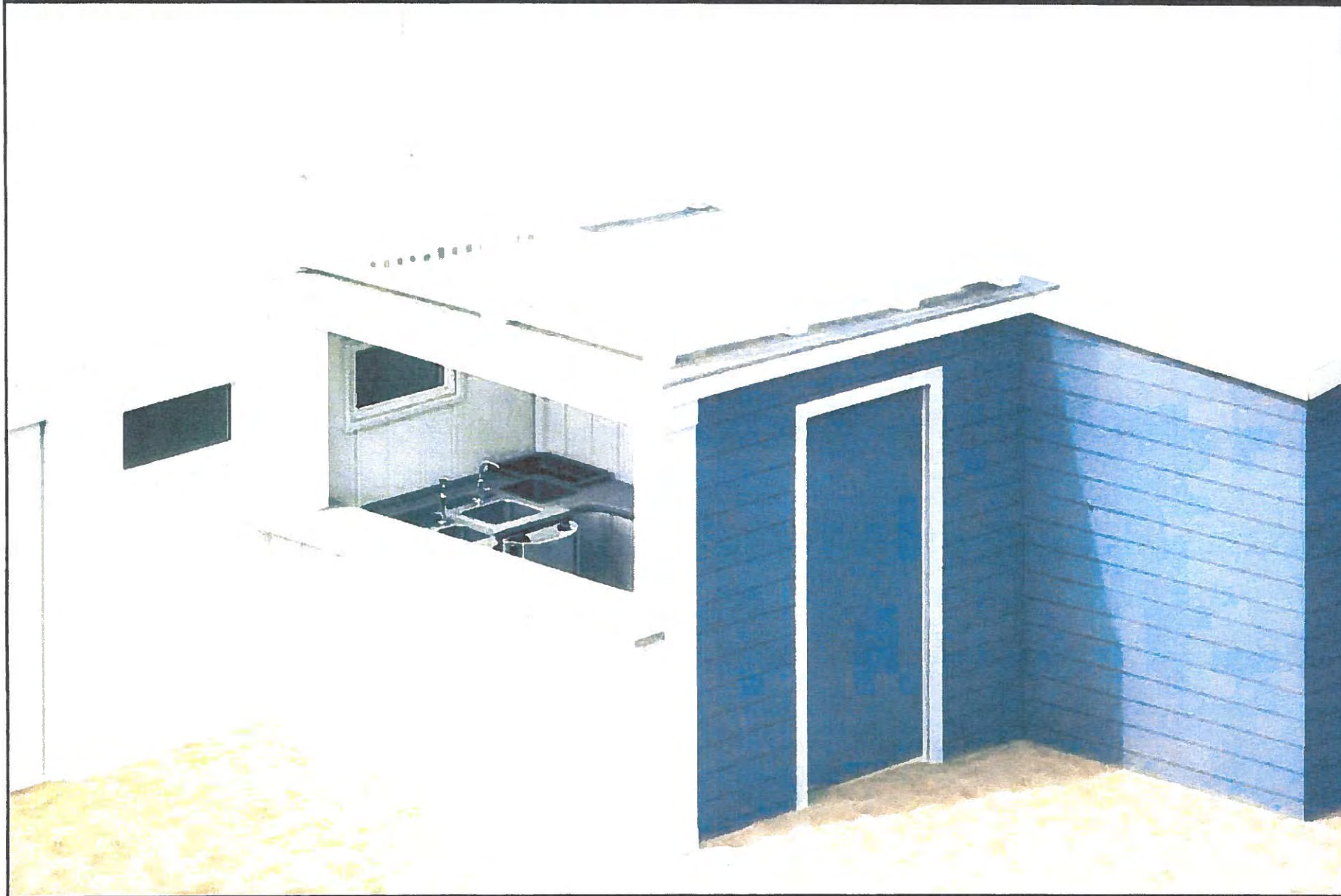



The Bearded Clam

April 16 at 5:02 PM



THIS FRI/SAT GRAND OPENING OF "THE BOSSMAN'S MUFF DIVER BAR! COME CELEBRATE WITH THE CLAM FAMILY AND SEE THE AMAZING OUTDOOR BAR CREATED BY Damian Mcalister AND THE CELTIC NATIONS CREW... DRINK SPECIALS AND GIVEAWAYS ALL WEEKEND! SLÀITÈ !

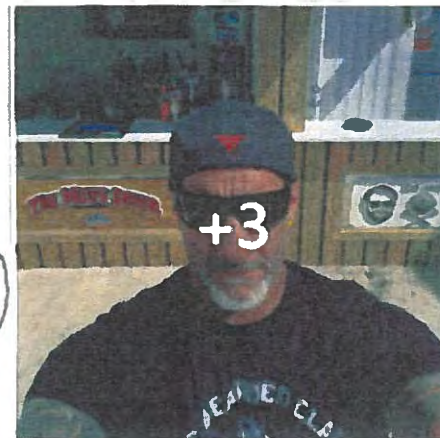
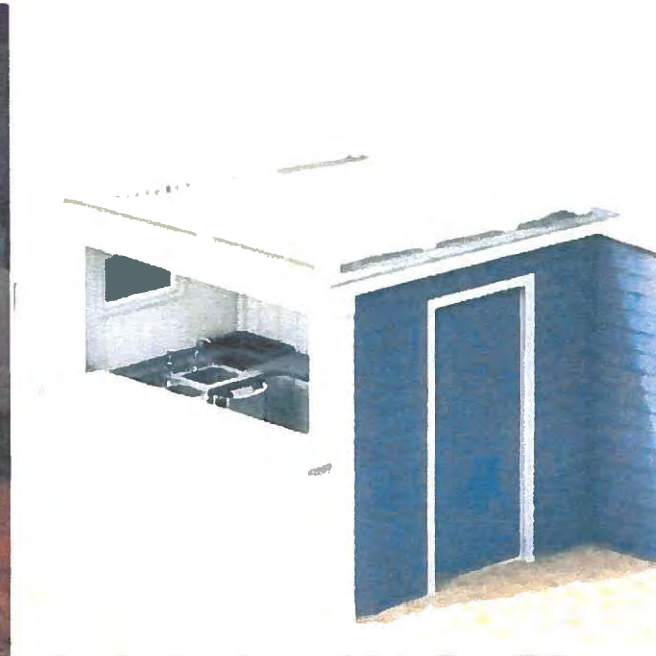
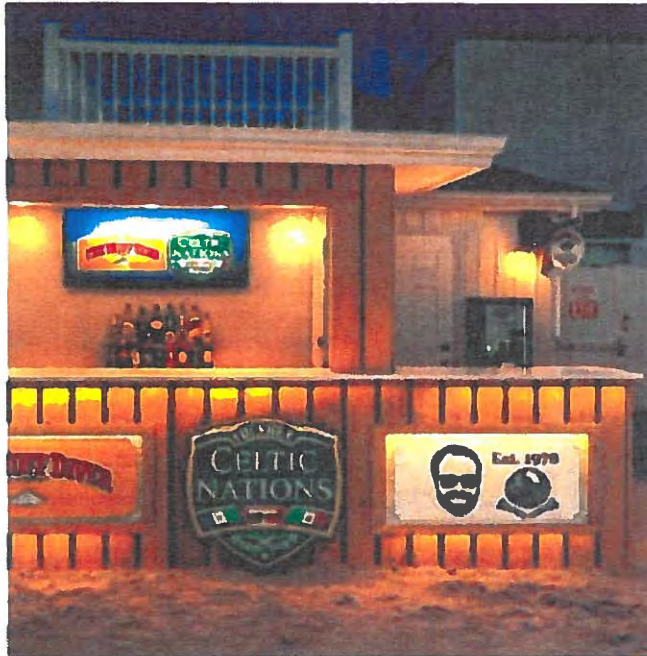

461 46 34



View more comments



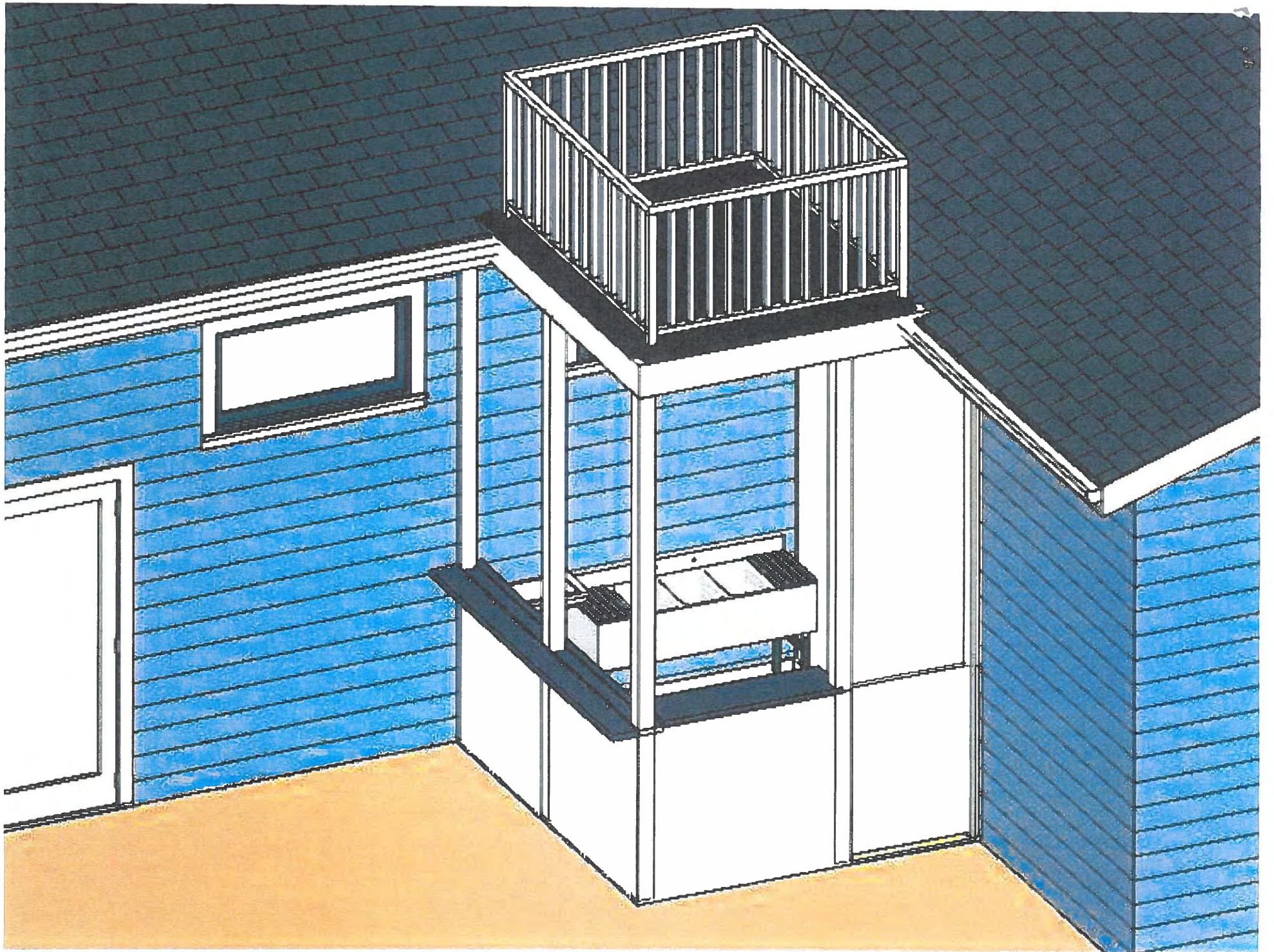

STORMWATER AND CRITICAL AREA REVENUE

(This work to be added to future improvements)

[Signature]
Signature

2/12/2025

Date

56 accumulative sq feet

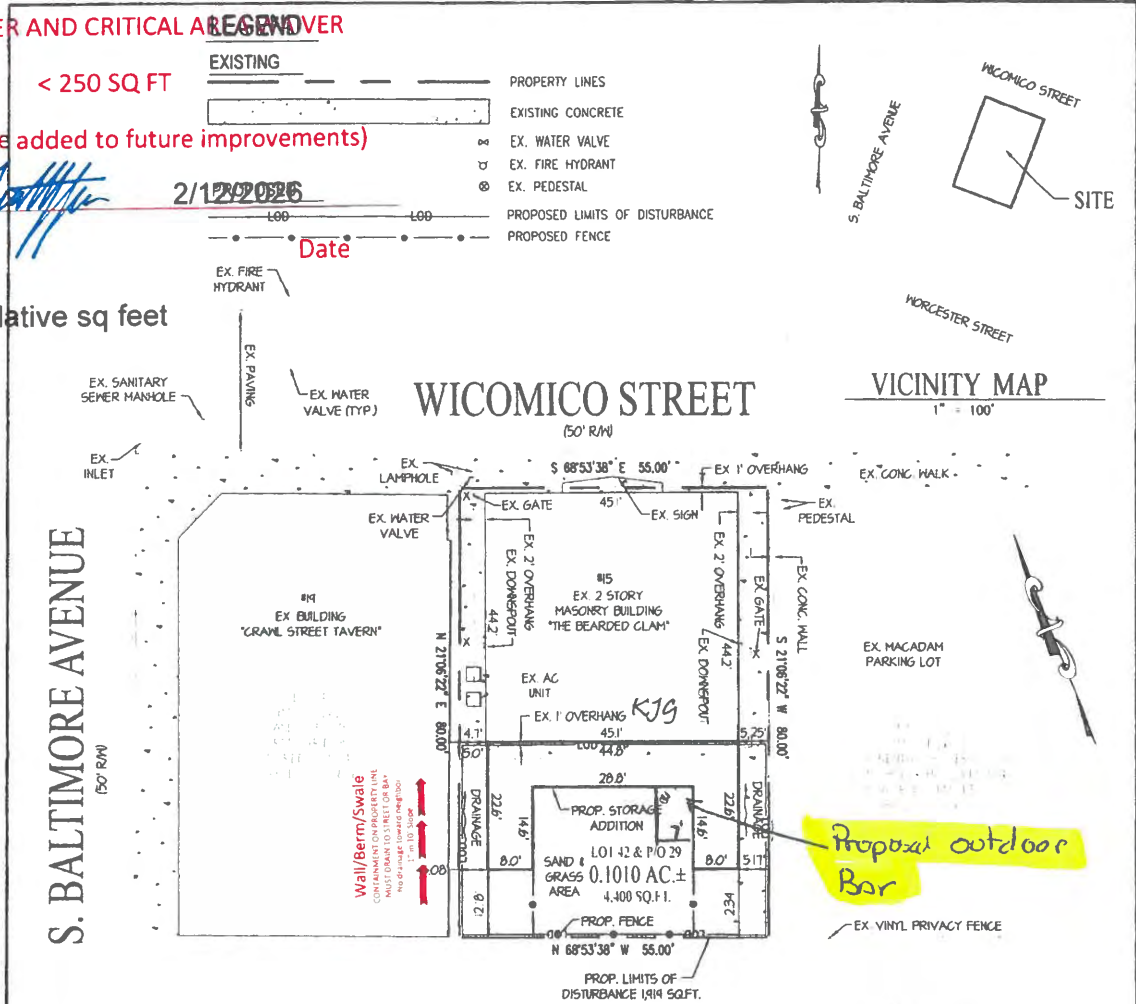

SITE DATA

#15 WICOMICO STREET
OCEAN CITY, MD 21842
LOT 42 AND P/O LOT 29
DEED REFERENCE: F.W.H. 623/423
PLAT REFERENCE: I.T.M. 4/538
PRESENT ZONING: B-1
(BOARDWALK COMMERCIAL DISTRICT)
TAX MAP NO. 110 PARCEL NO. 2623
TAX ID: 10-026571
EXISTING USE: 1ST FLOOR - TAVERN
2ND FLOOR - RESIDENTIAL
DRAINAGE FLOWS FROM REAR PROPERTY TO WICOMICO STREET.
PROP. LIMITS OF DISTURBANCE = 1,919 SQ.F.T.

PROPERTY IS LOCATED IN THE ATLANTIC COASTAL BAYS CRITICAL AREA IDA (INTENSELY DEVELOPED AREA).
PROPERTY IS LOCATED OUTSIDE THE 100' BUFFER.

EXISTING TOTAL IMPERVIOUS AREA

BUILDING/ROOF = 1,142 SQ.FT.
CONC. = 1,106 SQ.FT.

TOTAL IMPERVIOUS AREA = 2,248 SQ.FT.

TOTAL EXISTING LOT COVERAGE:

2,848 SQ.FT./4,400 SQ.FT. X 100 = 64.72%

EXISTING/PROPOSED LOT COVERAGE:

BUILDING/ROOF = 1,142 SQ.FT.
CONC. = 1,531 SQ.FT.
PROP. STORAGE BUILDING = 542 SQ.FT.

TOTAL IMPERVIOUS AREA = 3,265 SQ.FT.

TOTAL EXISTING/PROPOSED LOT COVERAGE:

3,265 SQ.FT./4,400 SQ.FT. X 100 = 74.20%

THIS PLAN REPRESENTS A 417 SQ.FT. INCREASE IN LOT COVERAGE



B-1 ZONING SETBACKS
FRONT = 0'
SIDEYARD = 5'
REAR YARD = 10'

NOTE: THIS SURVEY WAS PREPARED WITHOUT THE BENEFIT OF A TITLE REPORT AND/OR ABSTRACT.

REVISED 8-28-2024

I HEREBY CERTIFY, TO MY BEST KNOWLEDGE AND BELIEF, THAT THIS PLAT AND THE SURVEY IN WHICH IT IS BASED WAS MADE UNDER MY DIRECT SUPERVISION AND IS IN ACCORDANCE WITH CHAPTER 06, "MINIMUM STANDARDS OF PRACTICE," COMAR, TITLE 09, MARYLAND DEPARTMENT OF LABOR LICENSING AND REGULATION, PROFESSIONAL LAND SURVEYORS



OWNER
MIKE STRAWLEY
15 WICOMICO STREET
OCEAN CITY, MD 21842

SITE PLAN
TO ACCOMPANY BUILDING PERMIT APPLICATION
LOT 42 & P/O LOT 29
#15 WICOMICO STREET
THE BEARDED CLAM
THE TOWN OF OCEAN CITY
ELEC. DIST. NO. 10 WORCESTER COUNTY, MD

STH LAND SERVICES, LLC
LAND SURVEYING & ENGINEERING
EASTERN DIVISION
41 COASTAL DRIVE
BERLIN, MD 21811
443-513-8738

SCALE: 1"=20' DATE: 8-15-2024 DRAWN: M/N JOB NO.: E-24-048

This document has been reviewed and approved for compliance in accordance with The Zoning Code of the Town of Ocean City. Any changes from the approved construction documents shall be submitted for review and approval prior to the commencement.

Chase Phillips

Chase Phillips | Zoning Analyst

02/12/2026 - LESS THAN 100% OF GROSS FLOOR AREA OF BAR - NO ADDITIONAL PARKING ASSESSED.

These construction documents have been reviewed & approved for code compliance in accordance with the 2021 IBC, 2021 IRC, 2020 NEC, and the Town of Ocean City code of ordinances, and reviewed for Floodplain Compliance. Any changes from the approved construction documents shall be submitted for review & approval prior to the start of the work

ALL PLANS SUBJECT TO FIELD APPROVAL

Mike Brannagan

ICC Certified Building Plans Examiner
ICC Certified Accessibility Plans Examiner
02/25/2026

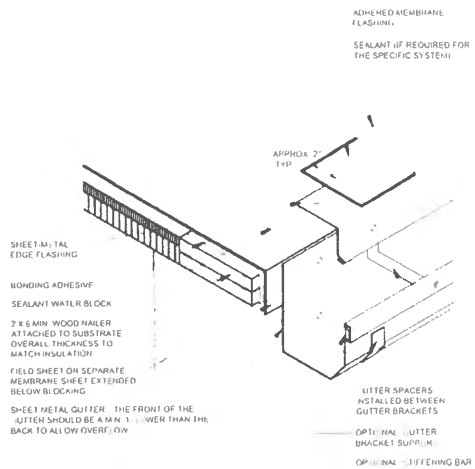

Rubber Roof Detail

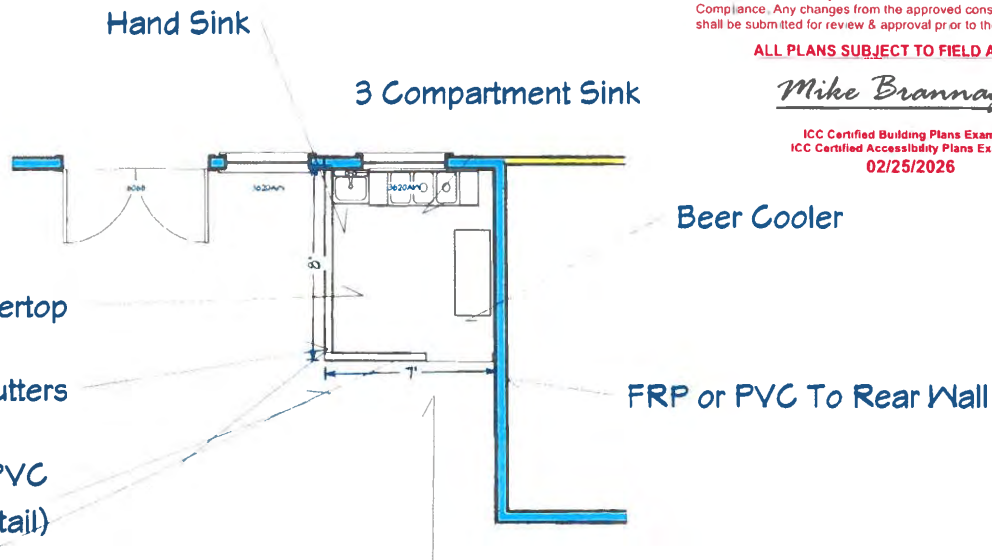

1st Floor

Composite Decking

FRP to interior of Bar and Ceiling

Bearded Clam
15 Wicomico St
Ocean City MD 21842

Celtic Nations Contracting
218 Charleston Road
Berlin MD 21811
MHIC: 67439

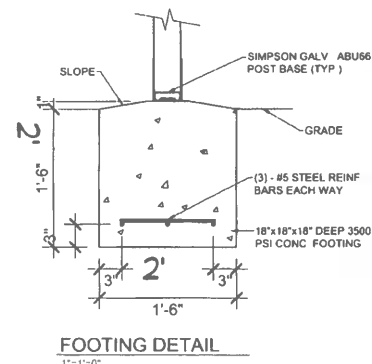
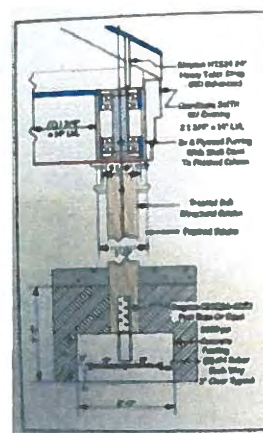

MIKE'S POST



3w Like Reply Share 1 ❤️



Lin Lecher-Jones
Brand new bar ! This bar is the best !



3w Like Reply Share 1 👍



Suzy Bruisey



3w Like Reply Share 1 😂 👍



Karen Marquess
we know it as there last september for bike week 😊 pretty cool 😎

3w Like Reply Share



Martin Reinsmith
Put Chip in the widows walk..

3w Like Reply Share



Dana Parks
Mike Strawley we're going to be down there Friday Springfest weekend, can I bring my chihuahua into Bossman's?

3w Like Reply Share



Suzy Bruisey
Mike Strawley careful for your answer she's a cowboys fan LOL 😂😂😂😂



Submit your first comment...



3w Like Reply Share



Patrick Ford

They spared no expense 😊

...

3w Like Reply Share



Michael Hillard

Its not new we were back there during hike week

3w Like Reply Share



Chris Shields

Bruce Jacob Barrett

...

3w Like Reply Share



Megan Collins

Olivia Christine

...

3w Like Reply Share 1 ❤️



David Bartelt

That changes everything

...

3w Like Reply Share



Montana Cassaro

Ally Shook Nick Marshall

...

3w Like Reply Share

2005-2006

Applications Must Be On Original Forms - No Copies Accepted - Must Be Completed IN BLACK INK ONLY!

WORCESTER COUNTY - STATE OF MARYLAND

Application for Renewal of Retail Alcoholic Beverage License No. 10

NOTE: This application must be filed on or before April 1st with the Board of License Commissioners of Worcester County. Otherwise, an entirely new application and advertisement for same will be required. All questions must be answered.

Individual () ; Partnership () ; Corporation () ; Unincorporated Association () ; Limited Liability Co. ()

Class of License now held: "D" Beer Day Renewal Fee: 4200.00

Growler - Refillable Container Permit: Yes () ; No () Renewal Fee (\$500):

To the Board of License Commissioners: Total Fee: 4200.00

Application is made by the undersigned under the provisions of Alcoholic Beverages Article of the Annotated Code of Maryland, as amended, for a renewal of the license now held, and the Applicant(s) submit(s) and certify(ies) to the following information required herein.

1. Workman's Compensation Policy No.: [Redacted] 11 am

2. Retail Sales Tax No.: [Redacted] Building permit 225-26

3. Corporate Name (if applicable): Mi-Lin inc

4. Applicant's Trade Name: The Beerers den

5. Business Email/Address: MIKE STRAWLEY@ricecentral.com

6. Applicants' Names, Residences, Individual Telephone Numbers and Individual Email Addresses.

If corporation, list all officers. Business Phone: 410 289 4478

a. Mike Strawley Pres. Address: [Redacted]
(Name) (Title)

Email: [Redacted] Telephone #'s: [Redacted]

b. KIM SUNDERS VP Address: [Redacted]
(Name) (Title)

Email: [Redacted] Telephone #'s: [Redacted]

c. 11 AM. Address: _____
(Name) (Title)

Email: _____ Telephone #'s: _____

7. Location of Licensed Premises: 15 Wilcomio St. Ocean 21442

a. Describe Premises in Detail: between Philadelphia and Atlantic Ave

b. Have there been any changes in the licensed premises during the past year?

If so, explain: Warehouse demolished - currently rebuilding

c. Proper Mailing Address For Establishment: 15 Wilcomio St Ocean 21442

8. All the facts and information contained in the original application as submitted are true and unchanged as of this time. TRUE FALSE _____

9. There is no person financially interested in the business to be conducted under this license, other than those listed herein. TRUE FALSE _____

WORCESTER COUNTY - STATE OF MARYLAND

APPLICATION FOR RENEWAL OF RETAIL ALCOHOLIC BEVERAGE LICENSE NO. 10

NOTE: This application must be filed on or before April 1st with the Board of License Commissioners of Worcester County. Otherwise, an entirely new application and advertisement for same will be required. **ALL QUESTIONS MUST BE ANSWERED.**

Individual () ; Partnership () ; Corporation (); Unincorporated Association () ; Limited Liability Co. ()

Class of License now held: "D" BEER/WINE/LIQUOR 7 DAY Renewal Fee: \$ 4,200.00

Growler - Refillable Container Permit: Yes () or No () Growler Fee (\$500): _____

Total Fee: \$ 4,200.00

To the Board of License Commissioners:

Application is made by the undersigned under the provisions of Alcoholic Beverages Article of the Annotated Code of Maryland, as amended, for a renewal of the license now held, and the Applicant(s) submit(s) and certify(ies) to the following information required herein.

2026-2027

1. Workman's Compensation Policy No. _____
2. Retail Sales Tax No.: _____
3. Corporate Name (it applicable): Mi-Lin inc _____
4. Applicant's Trade Name: The Bearded Clam _____
5. Business Email Address: _____

6. Applicants' Names, Residences, Individual Telephone Numbers and Individual Email Addresses.

If corporation, list all officers. Establishment Phone: (410) 289-3944 _____

a. michael strawlcy president Address: _____
(Name) (Title)

Email: _____

Phone: _____

b. karyn saunders vice president Address _____
(Name) (Title)

Email: _____

Phone: _____

c. _____ Address _____
(Name) (Title)

Email: _____ Phone: _____

7. Location of Licensed Premises: 15 wicomico st ocean city md 21842

a. Describe Premises in Detail bar located on wicomico st between atlantic ave & philadelphia

b. Have there been any changes to the Licensed Premises during the Past Year?

* If so, explain: wharehouse torn down outside bar and expand capacity

c. Mailing Address for Establishment: 15 wicomico st ocmd 21842

8. All the facts and information contained in the original application as submitted are true and unchanged as of this time. TRUE () FALSE ()

9. There is no person financially interested in the business to be conducted under this license, other than those listed herein. TRUE () FALSE ()



TOWN OF OCEAN CITY

The White Marlin Capital of the World

OCEAN CITY FIRE DEPARTMENT
OFFICE OF THE FIRE MARSHAL
P.O. BOX 158
OCEAN CITY, MARYLAND 21843

Office 410-289-8780
Fax 410-289-8767

February 5, 2026

Celtic Nation Contracting
218 Charleston Rd.
Berlin, MD 21811
443-614-3782
dee@celticnationllc.com

RE: PLAN REVIEW
Bearded Clam Outdoor Bar Addition
15 Wicomico St.
Ocean City, MD 21842

(x) PLANS

() INSUFFICIENT INFORMATION HAS BEEN SUBMITTED FOR REVIEW

As requested, we have reviewed your submittal for the above referenced project only. This review is limited to only those items that have been specified in the text of the submitted documents, and does not cover unsatisfactory conditions resulting from errors, omissions or failure to clearly indicate conditions.

Pursuant to the Code of the Town of Ocean City, all construction shall be in accordance with the Ocean City Fire Prevention and Protection Code and the Maryland State Fire Prevention Code, which adopts by reference the Life Safety Code, NFPA 101, 2024 edition, and NFPA 1 Fire Code, 2024 edition.

The owner and/or the owner' representative is responsible for contacting this office for scheduling of all required inspections. We reserve further comments during the visual site inspections.

The following attached comments are noted from a fire protection standpoint only:

Reviewed
Office of the Fire Marshal
Date: February 5, 2026
Reviewed by: Allison LeCates

AL

Deputy Fire Marshal
Tracking Number: 26-0228
This Review is based upon information contained in the submitted documents only, and does not cover unsatisfactory conditions resulting from errors, omissions or failure to clearly indicate conditions. Any alterations, additions or corrections to the documents must be re-submitted to this office for review.

MAYOR
RICHARD W. MEEHAN

CITY COUNCIL

MATTHEW M. JAMES
President

ANTHONY J. DELUCA
Secretary

PETER S. BUAS
JOHN F. GEHRIG, JR.
J. FRANKLIN KNIGHT
CAROL L. PROCTOR
WILLIAM C. SAVAGE III

CITY MANAGER
TERENCE J. MCGEAN, PE

CITY CLERK
DIANA L. CHAVIS, CMC

REQUIRED INSPECTIONS	
Firestop / Close-In	Kitchen Extinguishing System
Shaft wall	Kitchen Hood System
Sprinkler Hydro	Underground Hydro
Fire Alarm Final	Sprinkler Final X
Fire Pump Final	Final Inspection X

- 1) Based upon use, the occupancy classification is an assembly occupancy in accordance with NFPA 101, CH. 3.3.205.2 (2024).
- 2) Review and approval by the authority having a jurisdiction shall not relieve the applicant of the responsibility of compliance with the applicable codes and standards, NFPA 1, CH. 1.15.4 (2024).
- 3) The applicant shall be responsible to ensure that the following conditions are met:
 - (1) The construction documents include all of the fire protection requirements.
 - (2) The shop drawings are correct and in compliance with the applicable codes and standards.
 - (3) **The contractor maintains an approved set of construction documents on site.** NFPA 1, CH 1.15.2 (2024)
- 4) A copy of all review comments, memos, compliance sheets, plans and test sheets shall be made available on the job site upon request, NFPA 1, CH. 1.13.6.9 (2024)
- 5) In buildings under construction, adequate escape facilities shall be maintained at all times for the use of construction workers. Escape facilities shall consist of doors, walkways, stairs, ramps, fire escapes, ladders, or other approved means or devices arranged in accordance with the general principles of the Code insofar as they can reasonably be applied to buildings under construction. NFPA 101, CH. 4.6.10.3 (2024).
- 6) Where smoking is considered a fire hazard, the AHJ shall be authorized to order the owner in writing to post "No Smoking" signs in conspicuous, designated locations where smoking is prohibited. NFPA 1, Fire Code, 2024, 10.9.1
- 7) All fire protection systems and devices shall be maintained in a reliable operating condition and shall be replaced or repaired where defective or recalled. NFPA 1, CH. 13.1.8 (2024)

Appropriate modifications, where required, shall be made to the existing sprinkler system. This may include changes to the sprinkler coverage that are affected by the change in floor layout. Any required changes shall be submitted to this office for review and approval.

A sprinkler head shall be added underneath bar area.

- 8) The occupant load in any building or portion thereof shall be not less than the number of persons determined by dividing the floor area assigned to that use by the occupant load factor for that use as specified in Table 7.3.1.2, Figure 7.3.1.2(a), and Figure 7.3.1.2(b). Where both gross and net area figures are given for the same occupancy, calculations shall be made by applying the gross area figure to the gross area of the portion of the building devoted to the use for which the gross area figure is specified and by applying the net area figure to the net area of the portion of the building devoted to the use for which the net area figure is specified. NFPA 101, CH. 7.3.1.2* (2024).

Occupant load shall be calculated by the Fire Marshal's Office once project is complete.

- 9) Interior wall and ceiling finish materials complying with Section 10.2 shall be Class A or Class B in general assembly areas having occupant loads of more than 300 and shall be Class A, Class B, or Class C in assembly areas having occupant loads of 300 or fewer. NFPA 101, CH. 13.3.3.3 (2024).

Specification sheet on all interior finishes, furnishings, and decorations shall be submitted to this office for review prior to installation.

- 10) Electrical Systems. Electrical wiring and equipment shall be in accordance with NFPA 70, National Electric Code, unless such installations are approved existing installations, which shall be permitted to be continued in service.

Any new electrical installations shall be installed in accordance with NFPA 70, National Electric Code

Final Inspection

Prior to conducting the final required inspection by this office, the following is required:

- 1) The project is in compliance with all plan review comments.
- 2) As-built drawings must be submitted, at the assigned inspector's discretion, a minimum of five working days prior to final inspection.
- 3) Any or all requested cut sheets on materials used must be submitted a minimum of five working days prior to final inspection.
- 4) It is the responsibility of the owner and/or the owner's representative to contact this office for final inspection upon completion of all construction.

Note: if the above is not strictly adhered to, the final inspection must be re-scheduled.



PLANNING & COMMUNITY DEVELOPMENT
Building & Inspections Division

Town of Ocean City
permits@oceancitymd.gov
 Ocean City, MD 21842
 410-289-8855

PERMIT APPLICATION – SHORT FORM

APPLICATION # 26-0228

I. Project Information									
Address		15 Wicomico Street Ocean City MD 21842							
Project Description		Building a small outside bar, Install Fire door at top of stairs							
Construction Valuation		\$20,000.00							
II. Description of Work									
Demolition		Fence		Roofing & Siding		Plumbing			x
Electrical	x	HVAC/Mechanical		Marine		Shed/Accessory Structure			
Emergency Repair		Repair/Replacement		Paving		Other:			
III. Property Type									
Single Family		Duplex/Townhouse		Condominium		Multi-Family		Rental	Other:
IV. Contact Information									
Owner		Mike Strawley / Bearded Clam							
Address		15 Wicomico Street Ocean City MD 21842							
Phone Number		Email		mikestrawley@rocketmail.com					
Signature of Owner if Acting as Contractor X								Date	
Contractor		Celtic Nations Contracting							
Address		218 Charleston Road Berlin MD 21811							
Phone Number		Email		dee@celticionationsllc.com / simona.celticionations@gmail.com					
MHIC License No.		MHBR No.		OC Business License No.		24-00035594			
Signature of Contractor X Damian McAlister								Date	
2/2/2026									
<input checked="" type="checkbox"/> Electrical Contractor					<input type="checkbox"/> Mechanical Contractor				
ADDRESS					ADDRESS				
Teco Electric									
PHONE NUMBER		EMAIL			PHONE NUMBER		EMAIL		
443-783-4418									
MHIC License No.		State License No.		OC Business License No.		MHIC License No.		State License No.	
		13168		26-37907					
Signature of Electrical Contractor X								Date	
Plumbing Contractor		Steele Services			REQUIRED Plumbing Permit Application				
Address									
Phone Number		443-523-9057		Email					
MHIC License No.		State License No.		OC Business License No.		25-36782			
Signature of Plumbing Contractor X								Date	
IV. Add on Permits									
<input type="checkbox"/> Boardwalk Vehicle Permit \$50.00 per day					<input type="checkbox"/> Construction Equipment Permit \$50.00				
Start Date		End Date		Start Date		End Date			
Vehicle Type		Vehicle Weight		72 hours of City Right of Way use requires Certificate of Insurance					
Any closure of all or a portion of any city street, sidewalk, public parking space, or alley for the purposes of construction staging, material storage or other related use shall require a permit from the Town of Ocean City. Applicant shall submit a Certificate of Liability to the Engineering Department naming the Ocean City Mayor and City Council as additional insured in the amount of \$1,000,000 and a site plan showing location of City Right of Way use.									

SEE REVERSE FOR ADDITIONAL REQUIREMENTS THAT MAY BE REQUIRED WITH THIS APPLICATION

PERMIT APPLICATION – SHORT FORM (cont.)

APPLICATION #

Site Plan Requirement							
Applications for new construction, decks, fences, paving, HVAC equipment (exterior), sheds, and accessory structures shall be accompanied by a site plan showing any existing building or structure, all property lines with dimensions, all streets, easements, and setbacks. Show all utilities such as water, sewer, communication services, natural gas, telephone, and cable TV. Show all required parking, landscaping elements, drainage, and site grading information. Indicate drainage inflow and outflow locations and specify areas required to be maintained for drainage purposes. Show north arrow. Show dimensions for the location and size of components delineated on the site plan.							
Window/Glazing Information							
Residential structures less than 4 stories in height using these values will be deemed approved.							
DP Rating 45 (or higher)		SHGC 0.40 (or less)		Skylight U-Factor 0.55 (or less)		Window U-Factor 0.30 (or less)	
LOWER VALUES ARE PERMITTED BUT WILL REQUIRE A REVIEW, AND THE FOLLOWING:							
<i>DP Rating</i>	<input style="width: 40px;" type="text"/>	<i>SHGC</i>	<input style="width: 40px;" type="text"/>	<i>Skylight U-Factor</i>	<input style="width: 40px;" type="text"/>	<i>Window U-Factor</i>	<input style="width: 40px;" type="text"/>
<i>Height Above Grade</i>	<input style="width: 40px;" type="text"/>						
ALL OTHER WINDOWS WILL REQUIRE A REPORT BY AN ENGINEER.							
Emergency Repair Information							
Emergency repair permits are only permitted for work that is to prevent or abate immediate danger to life or property or as permitted by the building official. AC repair or replacement is not an emergency repair.							
A property owner or authorized agent shall apply for an emergency repair within 3 business days of the work.							
Emergency repair work is not authorization to continue work beyond what is necessary to abate immediate							
Roofing Information							
Replacement of asphalt shingles meeting ASTM D 7158G, ASTM D 7158H, ASTM D 3161 A, D, or F.							
Other roofing materials require an installation certification from an architect, engineer, or other approved							
Mechanical Information							
The short application is for HVACR equipment replacement or repair only.							
The short application for HVACR alterations and additions shall also include notification from an approved third-party agency that a Manual J, S, & D or engineered design has been reviewed and approved.							
The short application for HVACR equipment replacement for RTU's shall include the data plate of the existing equipment and the specs/data plate of the proposed equipment. If a significant weight difference exists, an analysis from structural engineer will be required with the application.							
Electrical Information							
Third-party review and approval may be required prior to permit issuance.							
Additional Information							

- The applicant attests that the information provided is true and accurate. If any information is found to be incorrect or if any information affecting the project or application changes, a stop work order may be placed on the project or actions taken until all corrections have been made.
- If a homeowner acts as a contractor and performs their own work, it is still unlawful for a homeowner to hire any person for construction activities. A homeowner is not permitted to perform any mechanical, electrical, plumbing or gas work.
- If the applicant is different than the owner, the applicant attests that permission has been given by the owner for the applicant to act as the authorized agent.
- If free labor or materials are provided, include an estimated fair market value for these items.

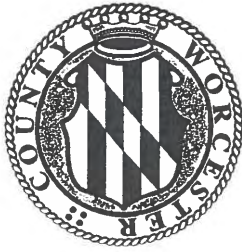

ALCOHOLIC BEVERAGE LICENSE

BOARD OF LICENSE COMMISSIONERS
WORCESTER COUNTY, MARYLAND

License #: 10

Class: "D"

Type: BEER-WINE-LIQUOR

7 DAY

Issued To: Michael J Strawley, Jr.
Karyn L Strawley Saunders

For: Mi-Lin, Inc.

Trading As:

BEARDED CLAM
15 Wicomico Street
Ocean City, MD 21842

Cost: \$4,250.00

Restrictions:

Comments:

Additional ownership information is available upon request. Please contact the Liquor License Administrator.

THIS LICENSE CERTIFIES that the above is licensed by the Board of License Commissioners of Worcester County pursuant to the authorities of Article 2B of the Annotated Code of Maryland to keep for sale and sell at retail alcoholic beverages as above stated at the above described premises.

For Class "B" and "D" licenses, alcoholic beverages may be consumed on and off the premises unless otherwise restricted. For Class "C" licenses, alcoholic beverages must be consumed on the premises only. For Class "A" licenses, alcoholic beverages must be sold in factory sealed containers which shall not be opened or consumed on the premises.

Alcoholic beverages may be sold under this license during those hours authorized by Article 2B of the Annotated Code of Maryland.

R. Charles Nichols, Chairman
Board Of License Commissioners

April R. Payne, Liquor License Administrator

Issued: May 01, 2026

Expires: April 30, 2027

TOWN OF OCEAN CITY
 PLANNING DEPARTMENT
 (410) 289-8855
 Official Building Permit
 * * * * *

Application Number [REDACTED] Date 2/25/26
 Application pin number [REDACTED]
 Property Address 15 WICOMICO ST
 Map and Parcel Numbers: 2623 -42 -6 - -0 -0110-026571
 Tax Account Number: [REDACTED]
 Tenant nbr, name BEARDED CLAM
 Application type description COMM - ALTERATION
 Subdivision Name
 Property Use RESTAURANT W/ DRIVE THRU
 Property Zoning BOARDWALK COMMERCIAL
 Application valuation 20000

Application desc
 BUILD AN OUTSIDE BAR, INSTALL FIRE DOOR

Owner	Contractor
MI-LIN INC	CELTIC NATIONS
15 WICOMICO ST	218 CHARLESTON RD
OCEAN CITY MD 21842	BERLIN MD 21811
	(443) 614-3782

Permit BUILDING PERMIT W/ FIRE REV
 Additional desc
 Permit Fee 380.00 Plan Check Fee 76.00
 Issue Date 2/25/26 Valuation 20000
 Expiration Date 6/25/26

Qty	Unit Charge	Per	Extension
		BASE FEE	95.00
15000.00	.0190	BD 5001-500K .019	285.00

Permit PLUMBING COMMERCIAL
 Additional desc 3 COMM NEW BAR
 Permit Fee 90.00
 Issue Date 2/25/26 Valuation 0
 Expiration Date 8/24/26

Qty	Unit Charge	Per	Extension
3.00	30.0000	FX PL COMMERCIAL FIXTURES	90.00

Special Notes and Comments
 2/13/2026, 10:29:29 AM FDOYLE
 final fixture count required

Other Fees IMPACT FEE-COM WATER 630.00

Disclaimer: Applicant warrants truthfulness of information in this permit. If any information is found to be incorrect, the application or permit issued under this permit may be revoked.

This permit must be displayed at all times.

TOWN OF OCEAN CITY
PLUMBING DEPARTMENT
(410) 524-6763
(410) 289-8705 FAX

Application Number [REDACTED] Page 2
Application pin number [REDACTED] Date 2/25/26

Other Fees IMPACT FEE-COM SEWER 1100.00

Fee summary	Charged	Paid	Credited	Due
Permit Fee Total	470.00	470.00	.00	.00
Other Fee Total	1730.00	1730.00	.00	.00
Grand Total	2276.00	2276.00	.00	.00

Disclaimer: Applicant warrants truthfulness of information
in this permit. If any information is found to be
incorrect, the application or permit issued under
this permit may be revoked.

This permit must be displayed at all times.

TOWN OF OCEAN CITY
 PLUMBING DEPARTMENT
 (410) 524-6763
 (410) 289-8705 FAX

Application Number [REDACTED] Page 3
 Date 2/25/26
 Property Address 15 WICOMICO ST
 Map and Parcel Numbers: 2623 -42 -6 - -0 -0110-026571
 Tax Account Number: [REDACTED]
 Tenant nbr, name BEARDED CLAM
 Application description COMM - ALTERATION
 Subdivision Name

Required Inspections

Seq	Insp Code	Description	Initials	Date
Permit type BUILDING PERMIT W/ FIRE REV				
10	BFN	BLDG FINAL INSPECTION	_____	___/___/___
10	FRNL	FIRE FINAL INSPECTION	_____	___/___/___
10	HDCO	HEALTH FOOD FINAL APPROVAL	_____	___/___/___
10	ZCO	ZONING FINAL INSPECTION	_____	___/___/___
10	FCLK	BLDG CLOSE-IN/FIRESTOP	_____	___/___/___
10	FRM	BLDG FRAMING INSPECTION	_____	___/___/___
10	EFNL	ELEC FINAL INSPECTION	_____	___/___/___
10	ECO	ENV FINAL INSPECTION	_____	___/___/___
10	601	FIRE FINAL INSPECTION	_____	___/___/___
Permit type PLUMBING COMMERCIAL				
10	PRI	PLMB ROUGH INSPECTION	_____	___/___/___
10	PFNL	PLMB FINAL INSPECTION	_____	___/___/___

Received 4-27-26
ARP

April 23 2026

April Payne, Liquor License Administrator
1 West Market St Snow Hill, MD 21863

Dear Ms. Payne,

This is Michael Strawley from the Bearded Clam , Ocean City Md. I am requesting a hearing as soon as possible for an expansion of licensed premise to include a new, enclosed outside bar on said property. The bar itself is 9x7 square feet and surrounding area for stand only encompasses 900 square feet. There will be high top tables (3) a cornhole board setup and another board game as well. Thank you for your time and consideration in this matter and hope to rectify the situation as smoothly as possible.

Sincerely,
Michael Strawley
The Bearded Clam
443-614-7847

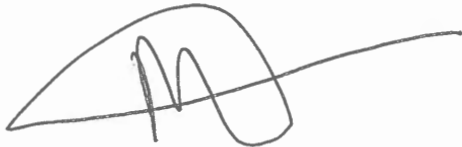
A handwritten signature in black ink, appearing to be 'M Strawley', with a long horizontal line extending to the right.



Worcester County

BOARD OF LICENSE COMMISSIONERS

2:20 –

Meeting/NAVBETS – Orlando H. Smack Jr., Chapter #0129
Special One Day Per Diem Application for June 27, 2026
Discussion to determine non-profit status
407A Tingle Street/Snow Hill



**BOARD OF LICENSE COMMISSIONERS
FOR WORCESTER COUNTY
NARRATIVE**

Type: *Non-Profit Status Revoked
Failure to file a 990-PF*

Date: 5/18/2026

License No: N/A

Class: N/A

Type: N/A

APPLICANT(S): 1. Karen Lewis 2.
 3. 4.

NON-PROFIT: *NAVETS – Orlando H Smack Jr.*

CORP: N/A

LOCATION: 407A Tingle Street, Snow Hill

Restrictions: N/A

On Friday May 16th, Liquor License Inspector, Joseph Pembroke, was conducting follow-ups on non-profit organizations that applied for Special One Day Per Diem Permits. Inspector Pembroke, through the Tax-Exempt Organization IRS website, (IRS.Gov/EO) found out that NABVETS -Orlando H. Smack Jr. with EIN #88-2936258, was listed as revoked for not filing a Form 990 series return for three (3) years. The IRS website states the revocation date as 05-15-2025 and the revocation posting date as 08-12-2025.

At the direction of Liquor License Administrator April Payne, Inspector Pembroke, called the IRS phone number 1-877-829-5500 at 4:08 p.m. on Monday May 18th and spoke with operator #103683 to validate the information on the IRS website. The operator said the non-profit (Orlando H. Smack Jr) organization was not in good standing because they did not file a tax form or return for the past three (3) past years. The operator did confirm what was on the IRS website as being correct and up to date.

The IRS Determination letter required the non-profit organization to **“file a Form 990-PF, Return of Private Foundation or Section 4947(a)(1) Trust Treated as Private Foundation annually, whether or not you have income or activity during the year. If you don’t file a required return or notice for three consecutive years, your exempt status will be automatically revoked.”** The effective date of exemption on the letter is 06-03-2022.

Joseph Pembroke
Liquor License Inspector

April Payne
Liquor License Administrator

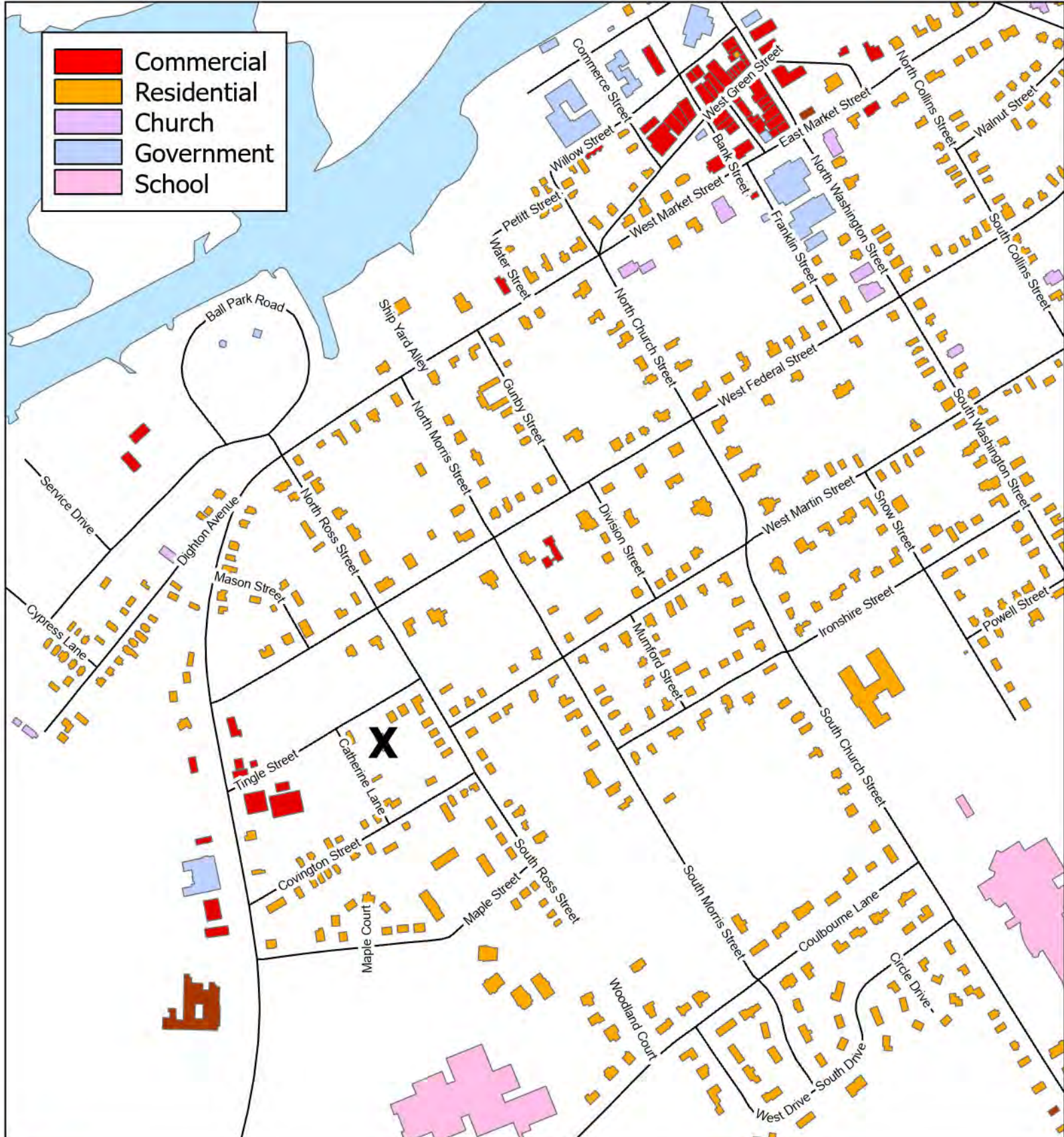

Worcester County Board of License Commissioners

Special One Day Per Diem Application
 June 27, 2026 - 407A Tingle Street
 Orlando H. Smack, Jr., Chapter #0129



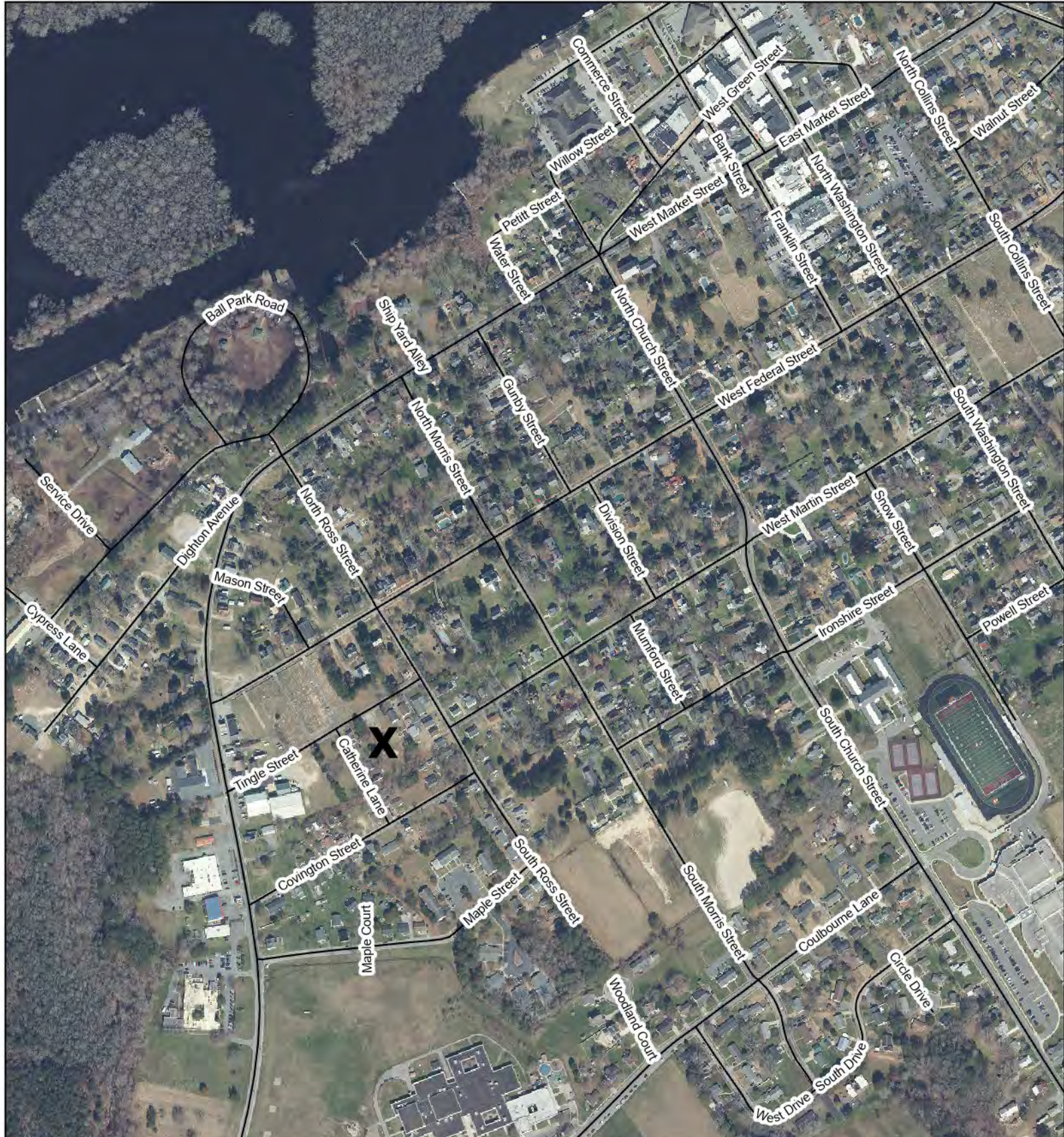

Worcester County Board of License Commissioners



Special One Day Per Diem Application
June 27, 2026 - 407A Tingle Street
Orlando H. Smack, Jr., Chapter #0129

Information & Technology - GIS Division - June 2026

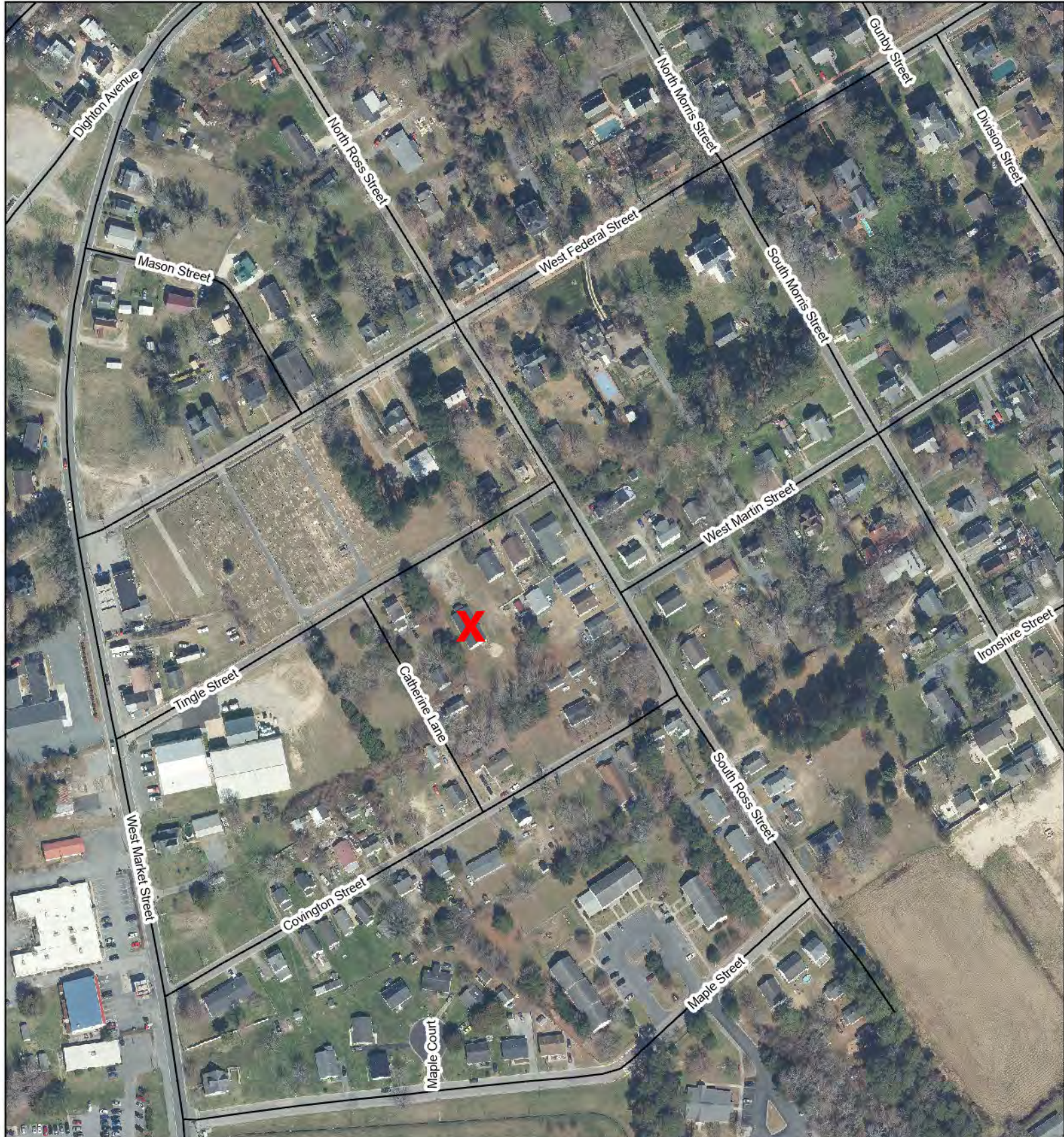

Worcester County Board of License Commissioners



Special One Day Per Diem Application
June 27, 2026 - 407A Tingle Street
Orlando H. Smack, Jr., Chapter #0129

Information & Technology - GIS Division - June 2026

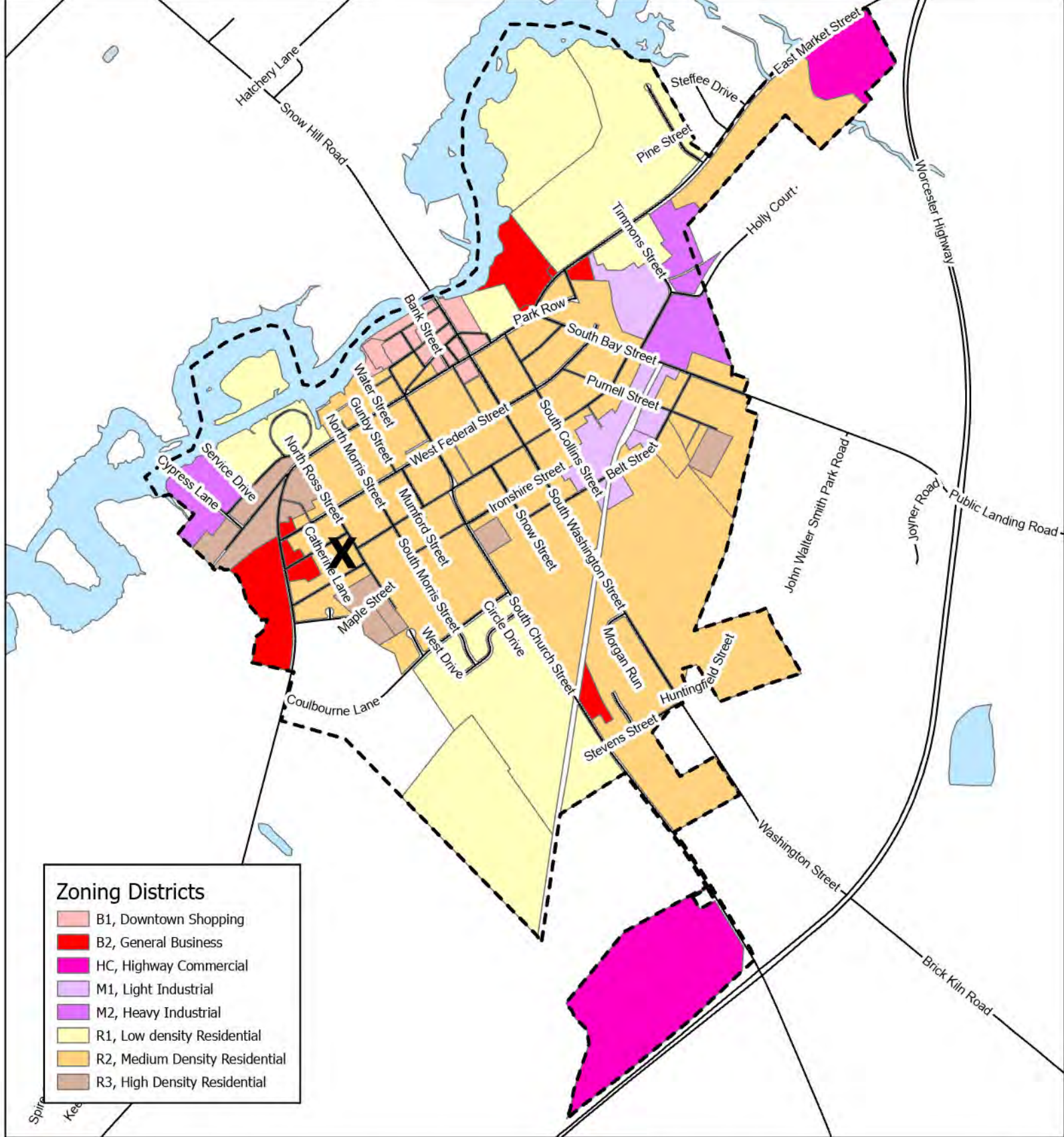

Zoning Districts

- B1, Downtown Shopping
- B2, General Business
- HC, Highway Commercial
- M1, Light Industrial
- M2, Heavy Industrial
- R1, Low density Residential
- R2, Medium Density Residential
- R3, High Density Residential



Worcester County Board of License Commissioners

Special One Day Per Diem Application
 June 27, 2026 - 407A Tingle Street
 Orlando H. Smack, Jr., Chapter #0129





Department of the Treasury
Internal Revenue Service
Tax Exempt and Government Entities
P.O. Box 2508
Cincinnati, OH 45201

ORLANDO H SMACK JR
PO BOX 231
SNOW HILL, MD 21836

Date:

06/27/2023

Employer ID number:

88-2936258

Person to contact:

Name: Customer Service

ID number: 31954

Telephone: 877-829-5500

Accounting period ending:

December 31

Form 990-PF required:

Yes

Effective date of exemption:

June 3, 2022

Addendum applies:

No

DLN:

26053571008553

Dear Applicant:

We're pleased to tell you we determined you're exempt from federal income tax under Internal Revenue Code (IRC) Section 501(c)(3). Donors can deduct contributions they make to you under IRC Section 170. You're also qualified to receive tax deductible bequests, devises, transfers or gifts under Section 2055, 2106, or 2522. This letter could help resolve questions on your exempt status. Please keep it for your records.

Organizations exempt under IRC Section 501(c)(3) are further classified as either public charities or private foundations. We determined you're a private foundation within the meaning of Section 509(a).

You're required to file Form 990-PF, Return of Private Foundation or Section 4947(a)(1) Trust Treated as Private Foundation, annually, whether or not you have income or activity during the year. If you don't file a required return or notice for three consecutive years, your exempt status will be automatically revoked.

If we indicated at the top of this letter that an addendum applies, the enclosed addendum is an integral part of this letter.

For important information about your responsibilities as a tax-exempt organization, go to www.irs.gov/charities. Enter "4221-PF" in the search bar to view Publication 4221-PF, Compliance Guide for 501(c)(3) Private Foundations, which describes your recordkeeping, reporting, and disclosure requirements.

Sincerely,

Stephen A. Martin
Director, Exempt Organizations
Rulings and Agreements

ORLANDO H SMACK JR

 United States

Auto-Revocation List

Organizations whose federal tax exempt status was automatically revoked for not filing a Form 990-series return or notice for three consecutive years.

Important note: Just because an organization appears on this list, it does not mean the organization is currently revoked, as they may have been reinstated.

Exemption Type: 501(c)(3) 

Exemption Reinstatement Date:

Revocation Date: 05-15-2025

Revocation Posting Date: 08-12-2025

Determination Letter

A favorable determination letter is issued by the IRS if an organization meets the requirements for tax-exempt status under the Code section the organization applied.

Final Letter(s)

[FinalLetter_88-2936258_ORLANDOHSMACKJR_06162023_00.pdf](#)
[\[/pub/epostcard/dl/FinalLetter_88-2936258_ORLANDOHSMACKJR_06162023_00.pdf\]](#)



Tax Exempt Organization Search

Select Database ?

Search By ?

Search Term ?

xx xxx xx xxxxx

RESET

SEARCH

[Search Tips](#)

⚠ Your search did not return any results. Try again.

Need Help? See [Search Tips](#) for guidance on effective searching, search criteria and logic, and selecting search terms.

OUR AGENCY

[About IRS](#)

[Careers](#)

[Operations and Budget](#)

KNOW YOUR RIGHTS

[Taxpayer Bill of Rights](#)

[Taxpayer Advocate Service](#)

[Independent Office of Appeals](#)

RESOLVE AN ISSUE

[IRS Notices and Letters](#)

[Identity Theft](#)

[Phishing](#)

LANGUAGES

[Español](#)

[中文\(简体\)](#)

[中文\(繁體\)](#)

RELATED SITES

[U.S. Treasury](#)

[Treasury Inspector General for Tax Administration](#)



Join / Sign in

OFF MARKET



← Search Overview Sale & tax history Property details Neighborhood Climate Favorite Edit Facts Share



407 Tingle St
Snow Hill, Maryland

 Google Street View

Jun 2023 [See more dates](#)

Share X



Department of Development Review & Permitting

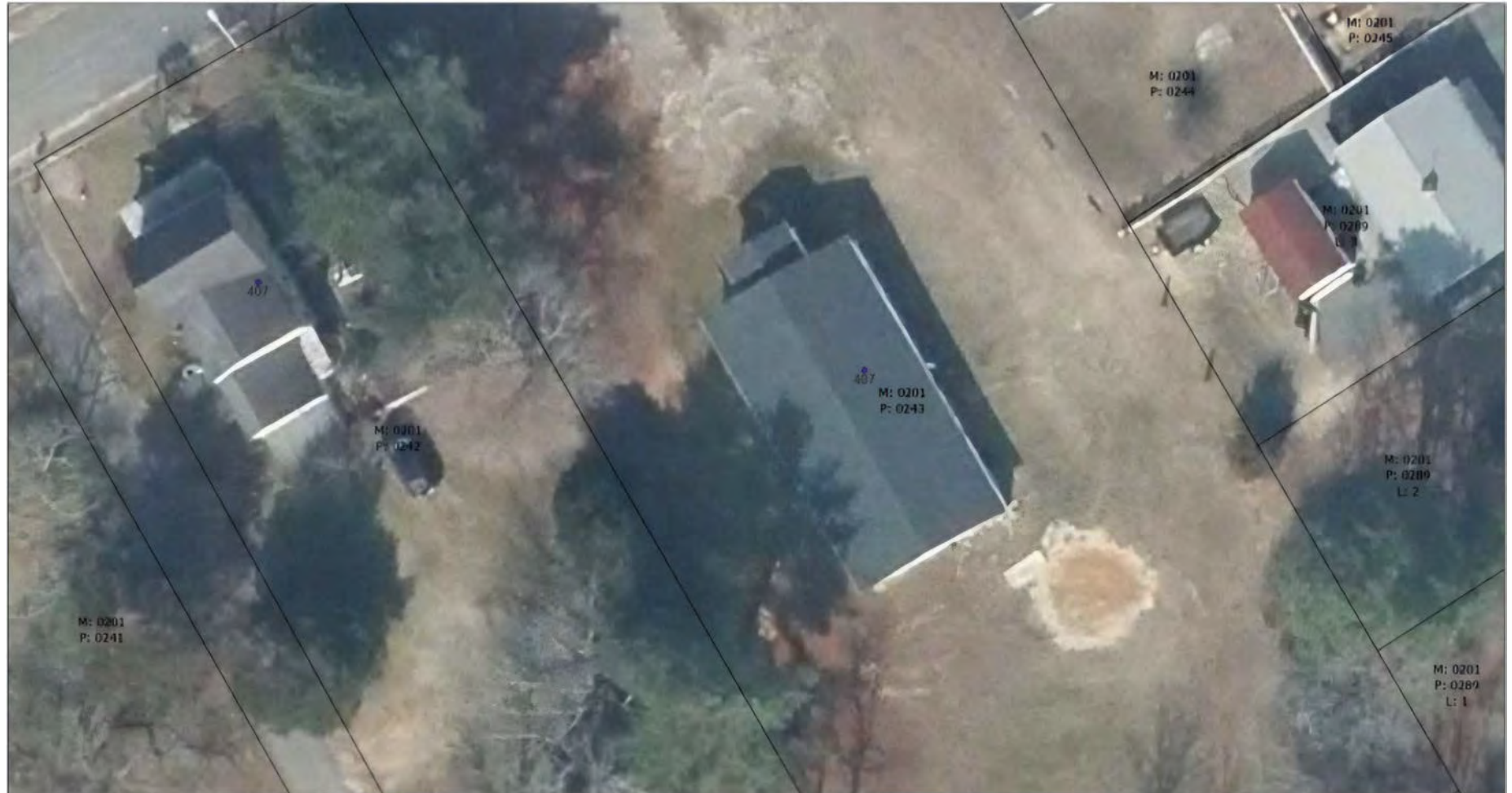

9/17/2025, 4:27:15 PM

• Addresses
sde.WORCESTERSDE.County_Bnd
Property Lines
LowerEasternShore 2024 TC 6in
Blue: Band 3

1:282
0 0 0.01 0.01mi
0 0 0.01 0.02km

BOARD OF LICENSE COMMISSIONERS FOR WORCESTER COUNTY



Attn: April R. Payne, Liquor License Administrator
Worcester County Government Center
One West Market Street, Room 1201
Snow Hill, Maryland 21863
Phone: 410-632-1908 Ext. 1120
Email: apayne@co.worcester.md.us

LD26-0070

APPLICATION FOR SPECIAL ONE DAY PER DIEM PERMIT

Deadline: Submit 30 days prior to event

TO BONA FIDE CONVENTIONS AND SUCH OTHER SPECIAL GROUPS UNDER THE
PROVISIONS OF THE MARYLAND ALCHOLIC BEVERAGES ARTICLE

Tax Identification Number: [REDACTED] Date of Application: 05/26/2026

Name of Non-Profit: NABVETS - Orlando H. Smack Jr. Chapter #0129

Applicant Information:

First Name: Karen Last Name: Lewis

Address: 407 Tingle St Apt/Suite: _____

City: Snow Hill State: MD Zip: 21863

Telephone: [REDACTED] Email: [REDACTED]

Event Information:

Event Name: Comedy Show and Disco

Event Location Address: NABVETS Chapter Building - 407 Tingle St Apt/Suite: _____

City: Snow Hill State: MD Zip: 21863

Description/Location for which Permit is sought:

This event will consist of an adult stand up comedy show with a disco following. All activity will be conducted inside the facility with the sale of food and adult beverages. Security will be present and no drinks will be permitted to enter or exit the building.

Thank You

Date(s) for Which Permit is sought:

Day 1: 06/27/2026 Hrs.: 6:00pm - 12:00am Day 2: _____ Hrs.: _____

Day 3: _____ Hrs.: _____ Day 4: _____ Hrs.: _____

Day 5: _____ Hrs.: _____ Day 6: _____ Hrs.: _____

() Beer: \$100 per day () Beer-Wine: \$100 per day (**X**) Beer-Wine-Liquor: \$100 per day

If event is held within an incorporated town, the Mayor & Council must approve issuance Permit and sign below

APPROVAL OF MAYOR & TOWN COUNCIL:

SIGNATURE OF APPLICANT:

APPLICANT MUST SIGN BOTH PAGES – SEE REVERSE

APPLICATION FOR SPECIAL ONE DAY PER DIEM PERMIT

1. Applicants may purchase beer & wine from a license **Maryland Wholesaler** or a licensed **Maryland Retailer** and liquor from a licenses **Maryland Retailer**.
2. No other person or entity, including licenses retailers and/or distributors, and/or breweries, and /or manufacturers may bring ANY alcoholic beverages on the premises.
3. Only the beer, wine, and liquor that the organization has purchased from licensed Maryland wholesalers or licensed Maryland retailers is permitted on the premises – PERIOD. This is the written State Law and the Maryland Comptroller’s rules and regulations, which carry the same weight as law. No person can make exceptions to these laws. Only the Maryland legislature can change the law.
4. The profits from the sale of alcoholic beverages under this permit are solely for the benefit of the applicant. Payment of sharing of any profits with a third party is a violation of the alcoholic beverage law.
5. This applicant may not use or hire a promoter to operate or conduct the event that is the subject of this application.

As the applicant for the foregoing Application for Special One Day Per Deim Permit; I certify that I have read the foregoing guidelines and agree to abide by them; and that I understand that a violation of these Rules and laws could result in a fine up to \$4000.00 levied against the organization named in the applications, and that any future applications on behalf of this group may be denied.

Karen Lewis

APPLICANT PRINT NAME:



SIGNATURE OF APPLICANT:

05/26/2026

DATE:

APPLICANT MUST SIGN BOTH PAGES – SEE REVERSE